

ICONE

HONEY

CO CERASA®

ICONE

HONEY

CO CERASA®

EN The HONEY collection is expressed in a precious and versatile furnishing system. Superb quality materials dress and interpret an iconic aesthetic for the bathroom, illuminated by the warmth of light that finds its place in details and play of references between fronts and mirrors in a design entirely engineered by Cerasa. Every detail has its own intrinsic uniqueness, the result of study and emotions translated into design, capable of exalting the characteristics of the environment within which they are placed. Just as in everyday life, honey represents something precious while in symbolism it embodies spiritual values and riches, so the Honey collection by Cerasa, designed by the architect Michele Marcon, gathers within itself the perfect fusion between materials and elements of design, between nature and wonder. A majestic design whose details are revealed in the dialogue between unique environments, forms and finishes.

FR La collection HONEY se décline en un système d'ameublement précieux et polyvalent. Des matériaux de grande valeur, interprètes d'une esthétique emblématique pour la salle de bain, illuminée par la chaleur de la lumière qui pénètre dans les moindres détails et références, entre portes et miroirs, faisant partie d'un projet entièrement conçu par Cerasa. Chaque détail possède sa propre unicité intrinsèque, fruit de recherche et d'émotions transposées en projet et capables de mettre en valeur les caractéristiques de l'environnement dans lequel elles se glissent. Tout comme le miel représente, dans la vie de tous les jours, un bien précieux et incarne, dans le symbolisme, valeurs et richesses spirituelles, la collection Honey de Cerasa, conçue par l'architecte Michele Marcon, représente la fusion parfaite entre matériaux et éléments de design, entre nature et émerveillement. Un projet majestueux dont les détails sont révélés par le dialogue entre l'espace, les formes et les finitions uniques.

La collezione HONEY si declina in un sistema di arredo prezioso e versatile. Materiali pregiatissimi vestono e interpretano un'estetica iconica per il bagno, illuminata dal calore della luce che si inserisce in dettagli e rimandi tra frontali e specchi in un progetto ingegnerizzato interamente da Cerasa. Ogni particolare ha una sua unicità intrinseca, frutto di studio ed emozioni trasposte in design, capaci di esaltare i caratteri dell'ambiente in cui si inseriscono. Così come nella quotidianità il miele rappresenta un bene prezioso e nella simbologia incarna valori e ricchezze spirituali, così la collezione Honey di Cerasa, disegnata dall'architetto Michele Marcon, accoglie in sé la perfetta fusione tra materiali ed elementi di design, tra natura e stupore. Un progetto maestoso i cui dettagli si svelano nel dialogo tra ambienti, forme e finiture uniche.

INDEX



p.8 PROPORZIONI PERFETTE



p.18 ARMONIE MULTISENSORIALI



p.70 SINTONIE MATERICHE



p.80 BAGLIORI ESTETICI



p.28 OPERA CONTEMPORANEA



p.38 OASI DI COMFORT



p.90 EQUILIBRIO DI PROPORZIONI



p.100 POETICA DELLO SPAZIO



p.48 INTRAMONTABILE ELEGANZA



p.60 GEOMETRIE VARIABILI



p.110 CONFINI FLUIDI



p.120 SCENOGRAFIE COSMOPOLITE

Arredi che creano, col loro prestigio, nuovi significati e identità del benessere.

PROPORZIONI PERFETTE

EN PERFECT
PROPORTIONS
Furnishings that, with their
prestige, create new
meanings and identities
of well-being.

FR DES PROPORTIONS
IDÉALES
Des meubles qui, par leur
prestige, confèrent un nouveau
sens et une nouvelle identité
au bien-être.

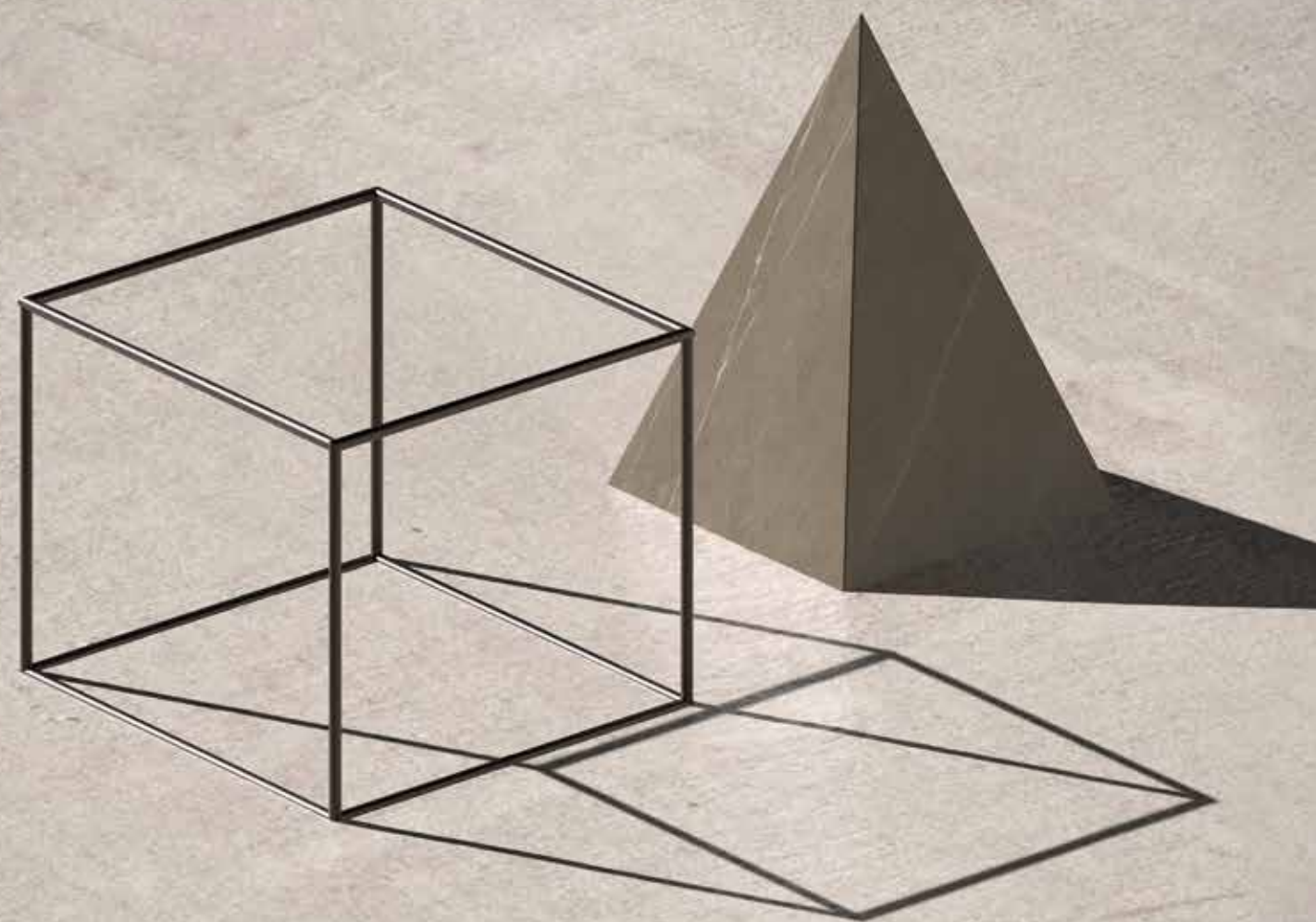



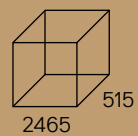
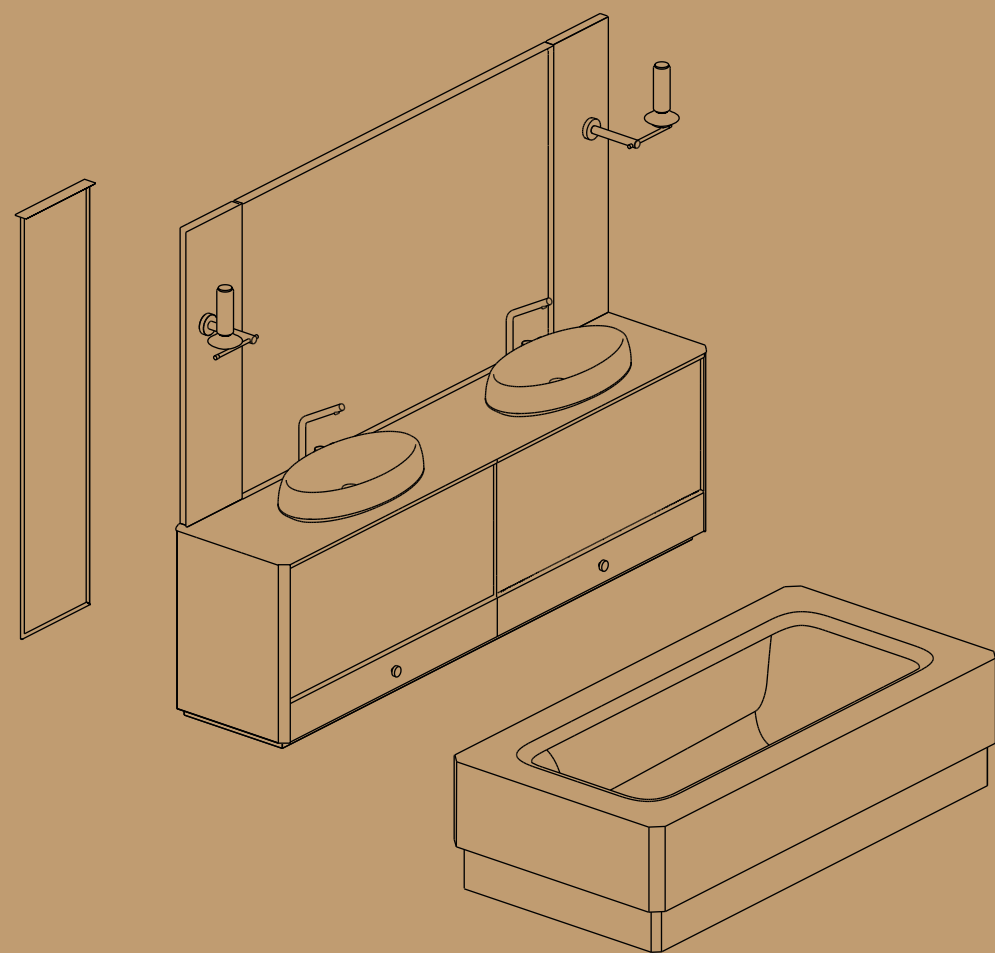

- **Mobile lavabo/Composition with washbasin units/Composition avec éléments sous-vasque**
Laccato opaco 11 Tortora liscio/3D
Smooth and 3D effect matt 11 Tortora lacquered
Laqué 11 Tortora mat lisse et avec effet 3D
- **Piano/Top/Plan de toilette**
Marmo Pietra Medea
Pietra Medea Marble
Marbre Pietra Medea

- | | | |
|---|------------------------------------|---|
| Elementi/Elements
Éléments | → Lavabo/Basin/Vasque
Pool 70M | → Portasciugamano/Towel holder/
Porte-serviettes |
| | → Vasca/Bathtub/Baignoire
Relax | Tonga |

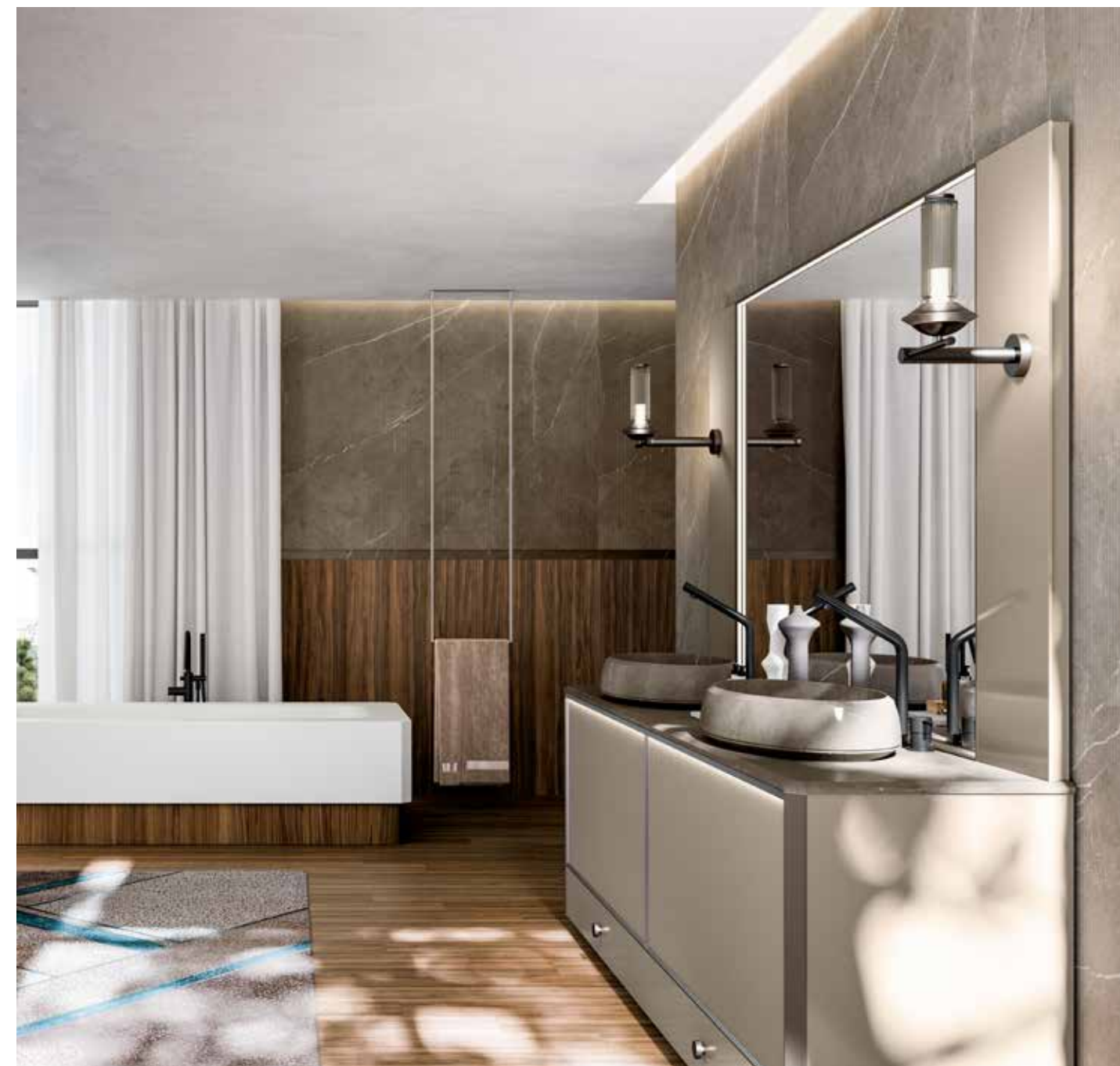



IT Di forte impatto estetico, il lavabo Pool 70M è realizzato in marmo Pietra Medea coordinato al top. Disponibile in più varianti.

EN With a strong aesthetic impact, the Pool 70M basin is made of Pietra Medea marble, coordinated with the top. Available in several versions.

FR A fort impact esthétique, la vasque Pool 70M est en marbre Pietra Medea, coordonnée au plan de toilette. Disponible en plusieurs versions.

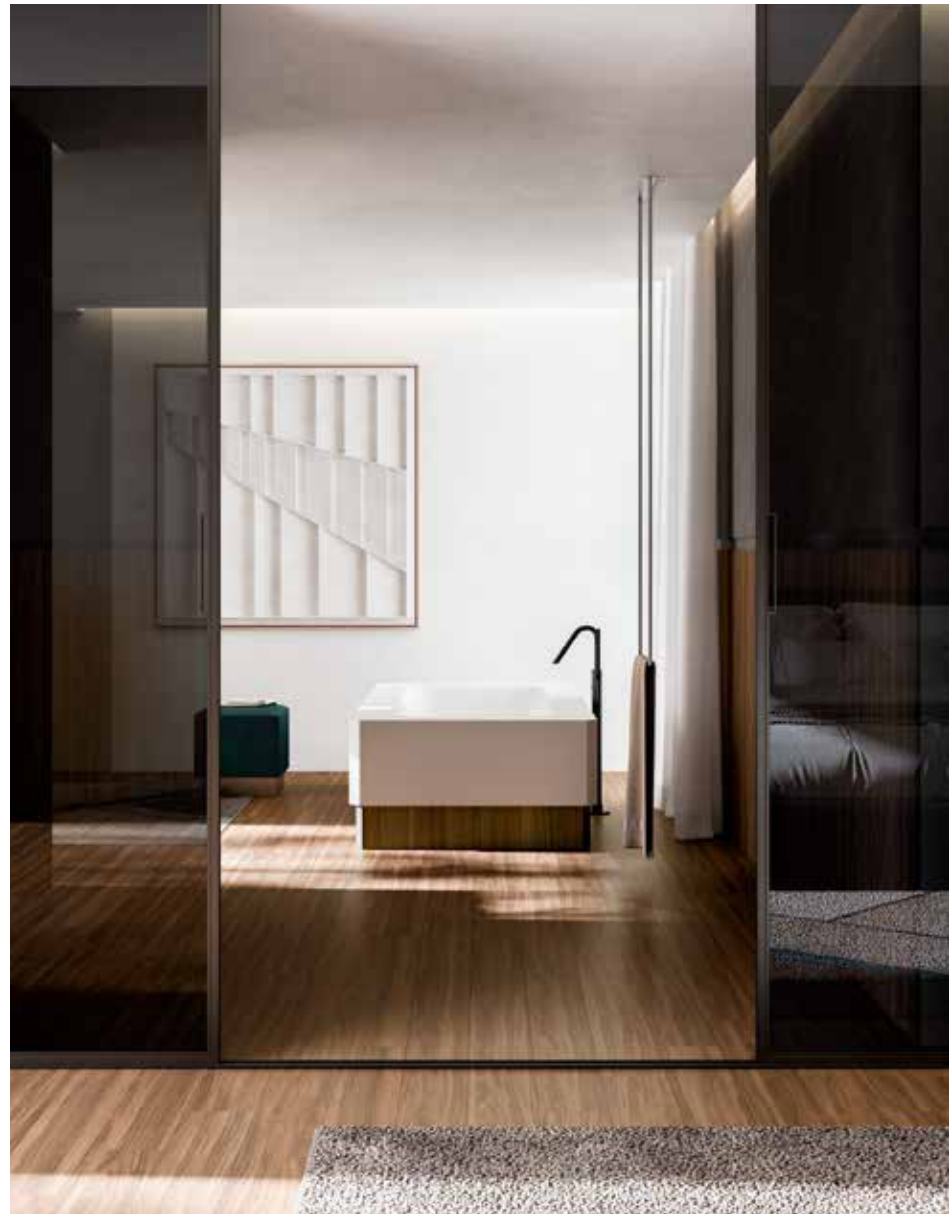

- IT** Dettagli inclinati ai lati della vasca Relax, particolari che ritornano in tutta la collezione. La parte inferiore, che a sua volta li riprende, è realizzabile in più finiture.
- EN** On the sides of the Relax bathtub, inclined details that return throughout the collection. The lower part, which in turn incorporates them, can be made in several finishes.
- FR** Sur les côtés de la baignoire Relax, des détails inclinés qui reviennent tout au long de la collection. La partie inférieure, qui à son tour les incorpore, peut être réalisée en plusieurs finitions.

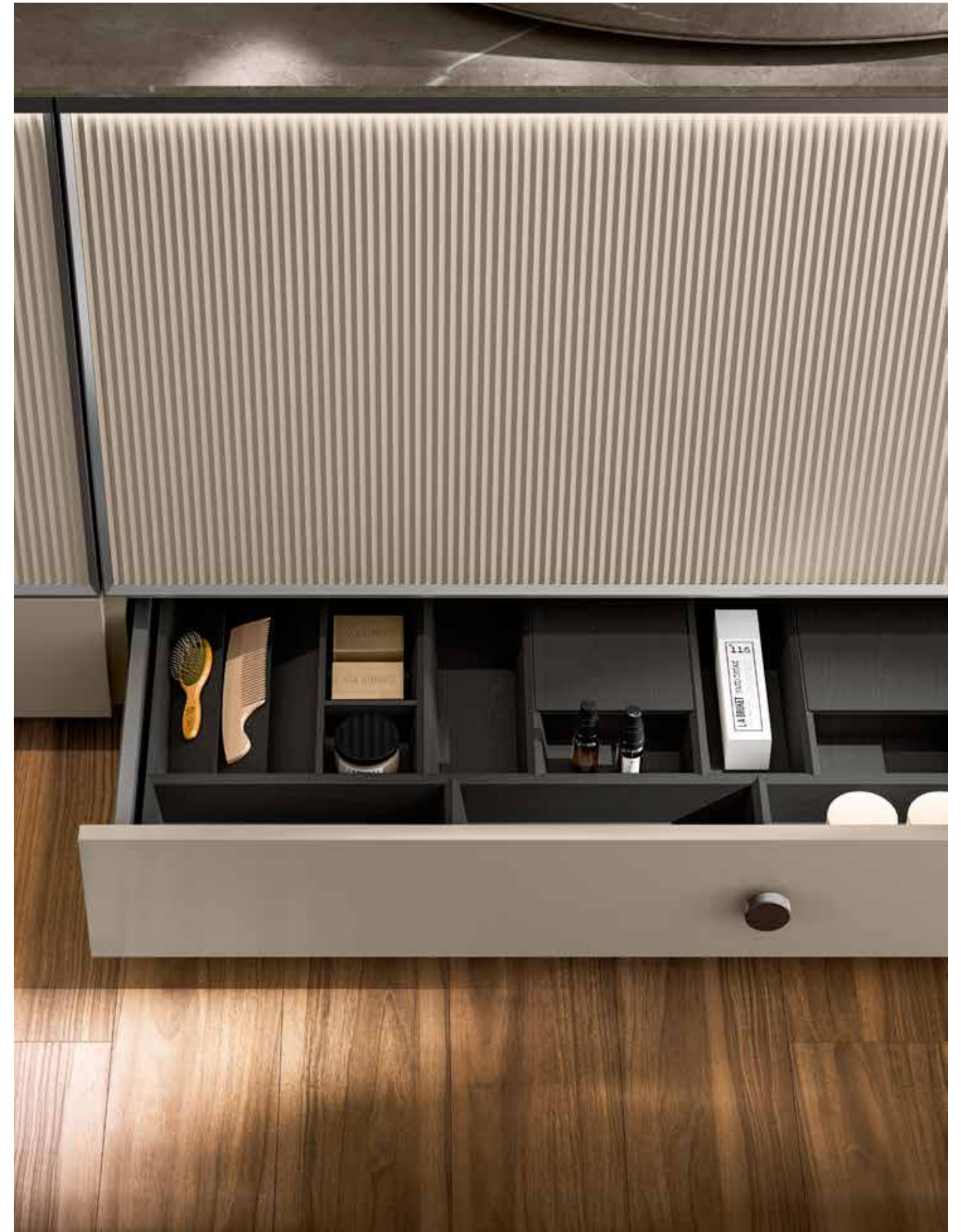

Isole sensoriali che esplicitano tutte le componenti uniche di cui è fatto il design.

ARMONIE MULTISENSORIALI

EN MULTISENSORIAL
HARMONIES
Sensorial islands expressing
all unique components
of which design is made.

FR HARMONIES
MULTISENSORIELLES
Des îlots sensoriels exprimant
tous les composants uniques
dont est fait le design.





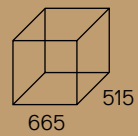
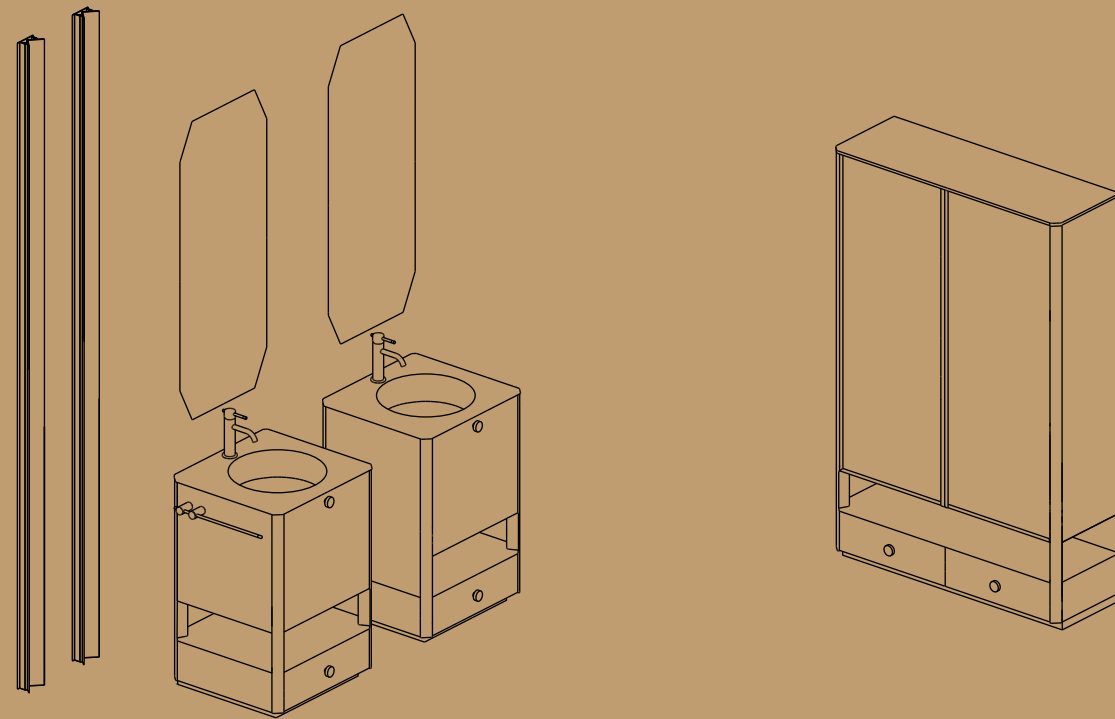

→ **Mobile lavabo/Composition with washbasin units/Composition avec éléments sous-vasque**
 Impiallacciato Noce Canaletto
 Noce Canaletto veneered
 Plaqué Noce Canaletto
 → **Piano lavabo/Top with integrated basin/Plan de toilette avec vasque moulée**
 Solysand

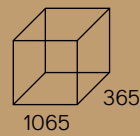

→ **Colonne/Hanging full-height units/Colonne**
 Impiallacciato Noce Canaletto/
 Cristallo specchiante
 Noce Canaletto veneered/
 Reflective glass
 Plaqué Noce Canaletto/
 Verre réfléchissant

Elementi/Elements → Lampade/Lamps/Lampes
Éléments Victoria

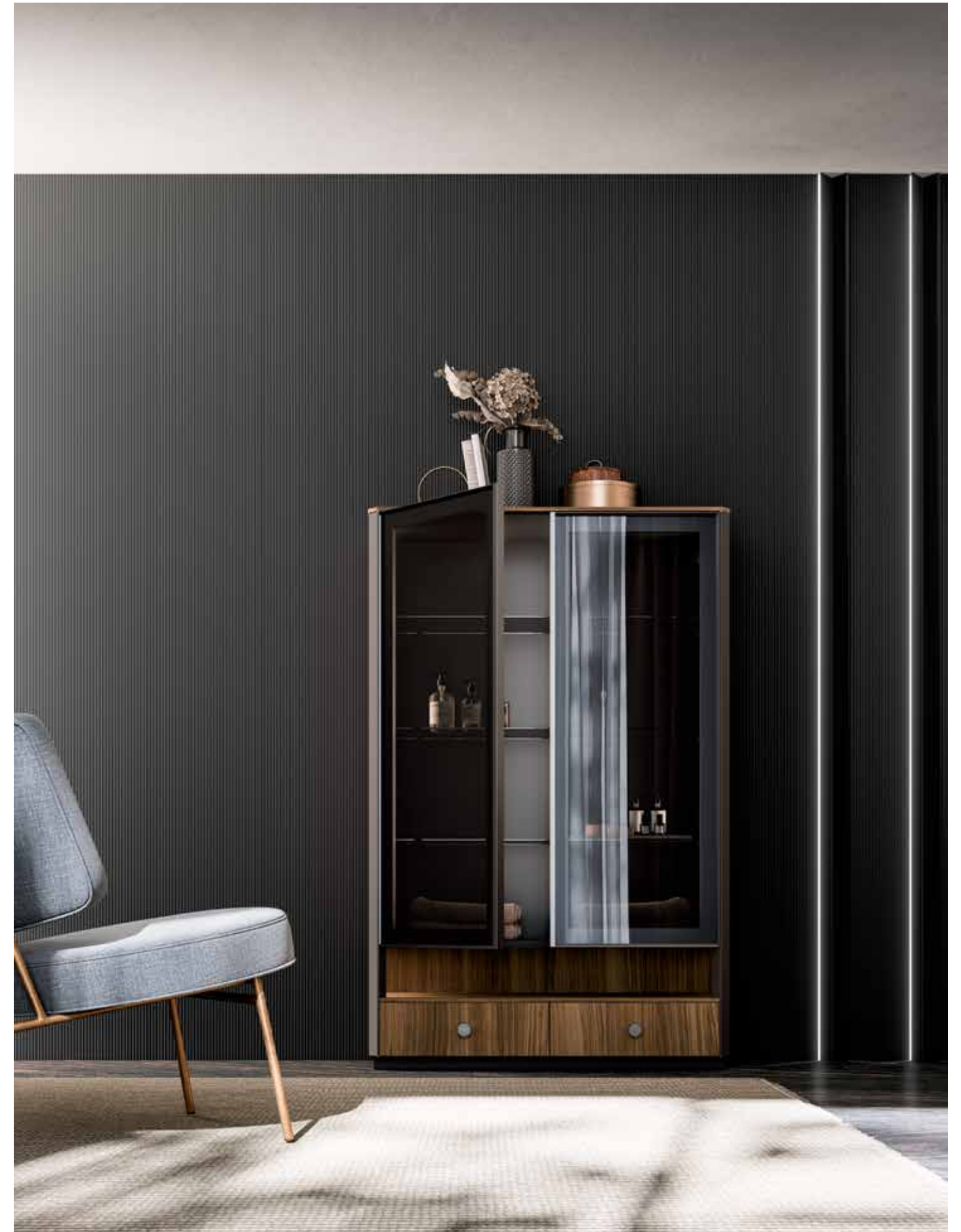



- IT** La particolare godronatura del pomolo è ripresa anche sulla leva del miscelatore: dettagli di stile che impreziosiscono e che rendono unica la collezione.
- EN** The particular scalloping of the knob is also repeated on the mixer's lever: details of style that enhance and make the collection unique.
- FR** Le moletage particulier de la poignée se retrouve sur le levier du mitigeur : détails de style qui embellissent la collection tout en la rendant unique.



- IT** La particolare forma a cilindro della vasca integrata, realizzata in Solysand, può essere realizzata con il fondo ispezionabile coordinato, o in alternativa nelle finiture a listino dei Laminam/Gres.
- EN** The particular cylinder shape of the integrated tank, made in Solysand, can be made with the coordinated inspectionable bottom, or alternatively in the Laminam/Gres finishes in the catalogue.
- FR** La forme cylindrique particulière de la baignoire intégrée, élaborée en Solysand, peut être réalisée avec le fond inspectable coordonné ou, en alternative, avec les finitions Laminam/Grès disponibles.



Nuova iconografia delle forme e delle luci
nell'eccezionale creatività della progettazione
moderna.

OPERA CONTEMPORANEA

EN CONTEMPORARY
WORK

New iconography of the shapes
and lights in the exceptional
creativity of its modern design.

FR UNE ŒUVRE
CONTEMPORAINE

Nouvelle iconographie des
formes et des lumières dans
la créativité exceptionnelle
de la conception moderne.

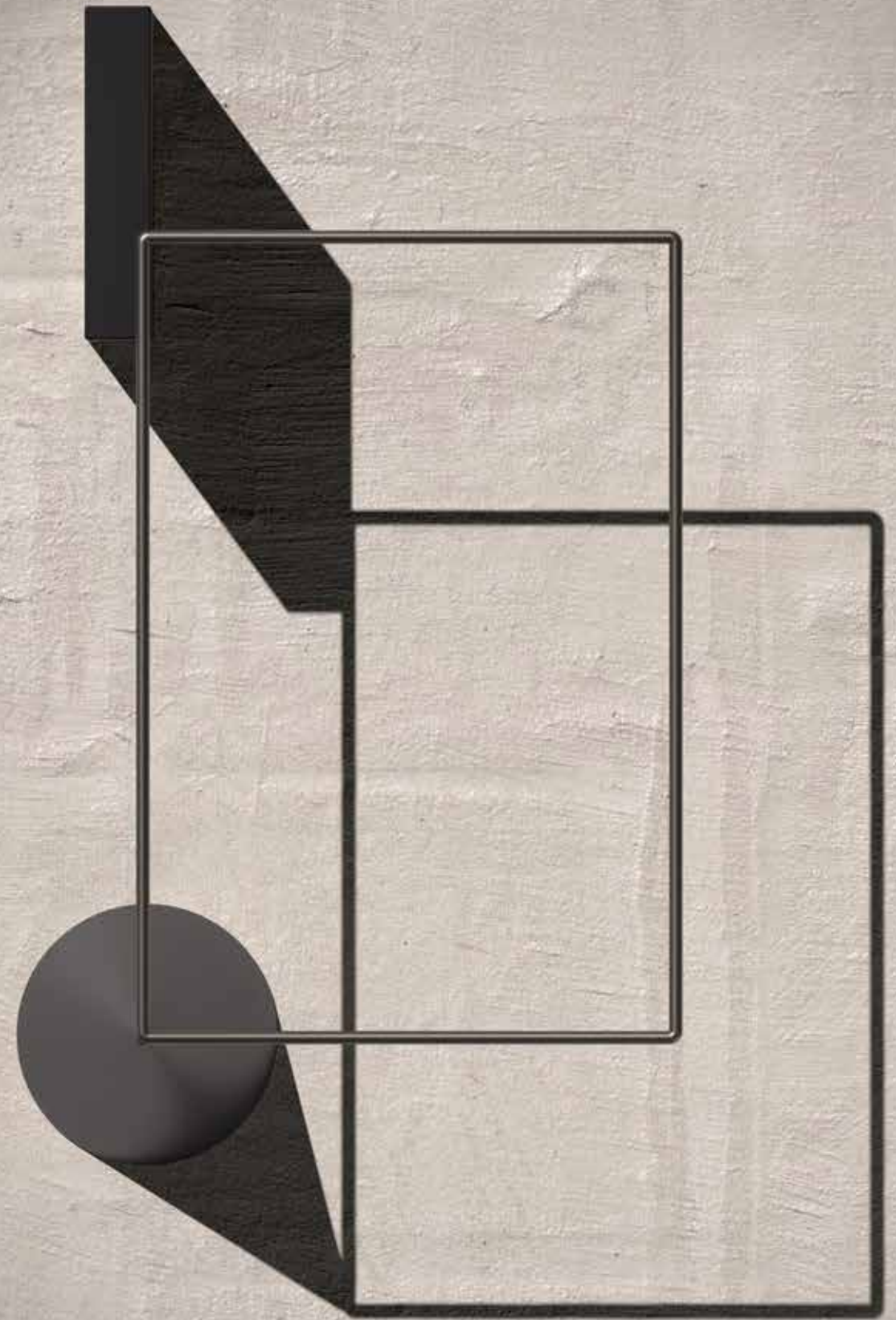



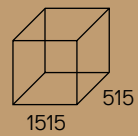
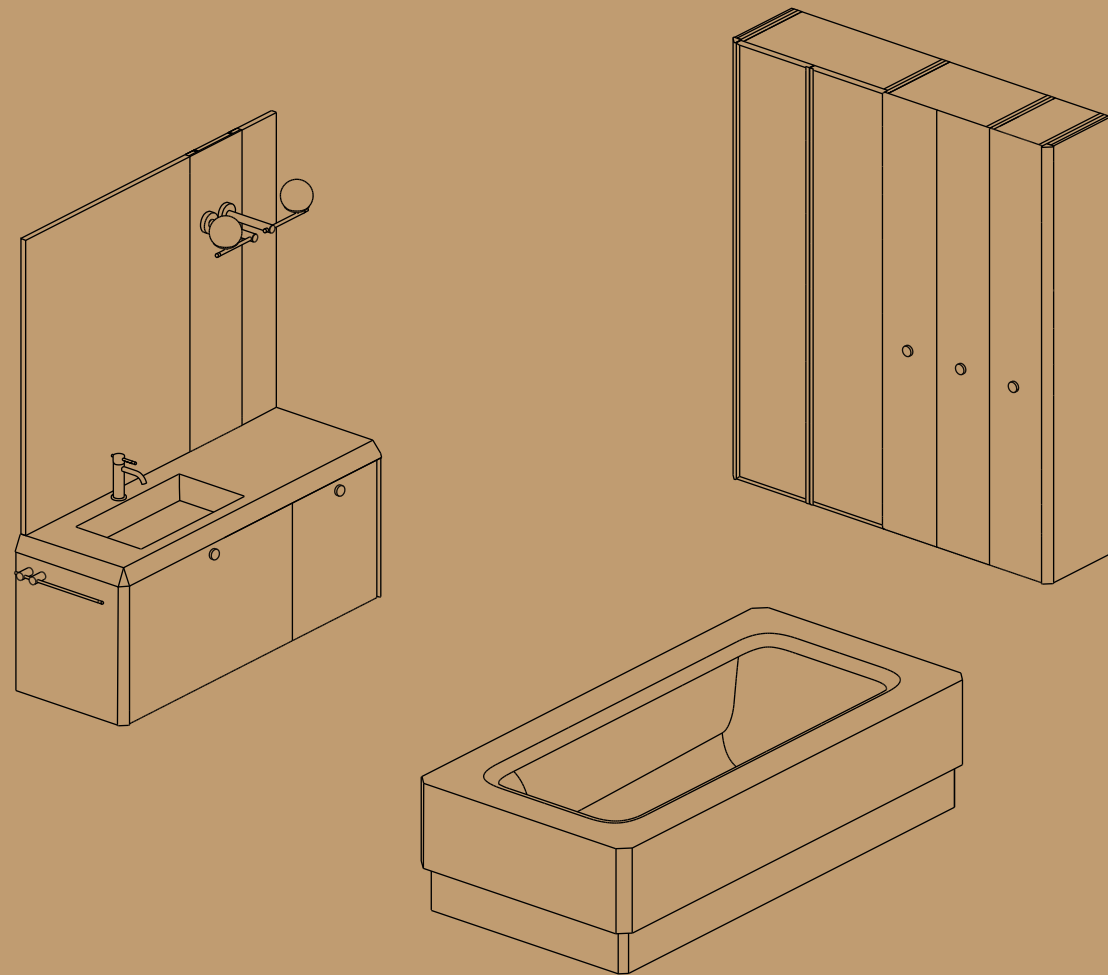

→ **Mobile lavabo/Composition with washbasin units/Composition avec éléments sous-vasque**
 Laccato opaco 14 Verde Acqua liscio/3D Smooth and 3D effect matt 14 Verde Acqua lacquered/Laqué 14 Verde Acqua mat lisse et avec effet 3D
 → **Piano lavabo/Top with integrated basin/Plan de toilette avec vasque moulée**
 Solysand

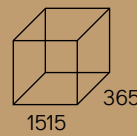

→ **Colonne/Hanging full-height units/Colonne**
 Laccato opaco 14 Verde Acqua 3D/Cristallo specchiante 14 Verde Acqua matt 3D effect lacquered/Reflective glass
 Laqué mat effet 3D 14 Verde Acqua/Verre réfléchissant

Elementi/Elements → Vasca/Bathtub/Baignoire
Éléments → Relax





IT I piani della collezione Honey riprendono le sfaccettature identificative della collezione e possono essere realizzati in più varianti, dando una resa estetica sempre nuova e mai scontata.

EN The tops of the Honey collection reflect the identifying facets of the collection and are available in several variations, giving an aesthetic appearance that is always new and never predictable.

FR Les surfaces de la collection Honey reproduisent les facettes typiques de la collection et peuvent être réalisées dans différentes variantes, résultant en un rendu esthétique toujours nouveau et jamais prévisible.





- IT** Tutto è stato creato per rendere Honey un modello unico: le luci in vetro lavorato con due forme diverse, esaltano le composizioni, donando un'atmosfera intima e piacevole.
- EN** Everything has been created to make Honey a unique model: the glass lights processed with two different shapes enhance the compositions, providing an intimate and attractive atmosphere.
- FR** Tout a été créé dans le but de faire de Honey un modèle unique : les lumières en verre travaillé comprenant deux formes différentes mettent en évidence les compositions, conférant une atmosphère intime et agréable.



Essenzialità creata dalla sapiente sintesi dei materiali,
dei colori e dei dettagli di stile.

OASI DI COMFORT

EN OASIS OF COMFORT
Essentiality created by the wise
synthesis of materials, colours
and details of style.

FR UNE OASIS DE CONFORT
Essentialité créée par la synthèse
savante des matériaux, des
couleurs et des détails de style.





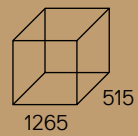
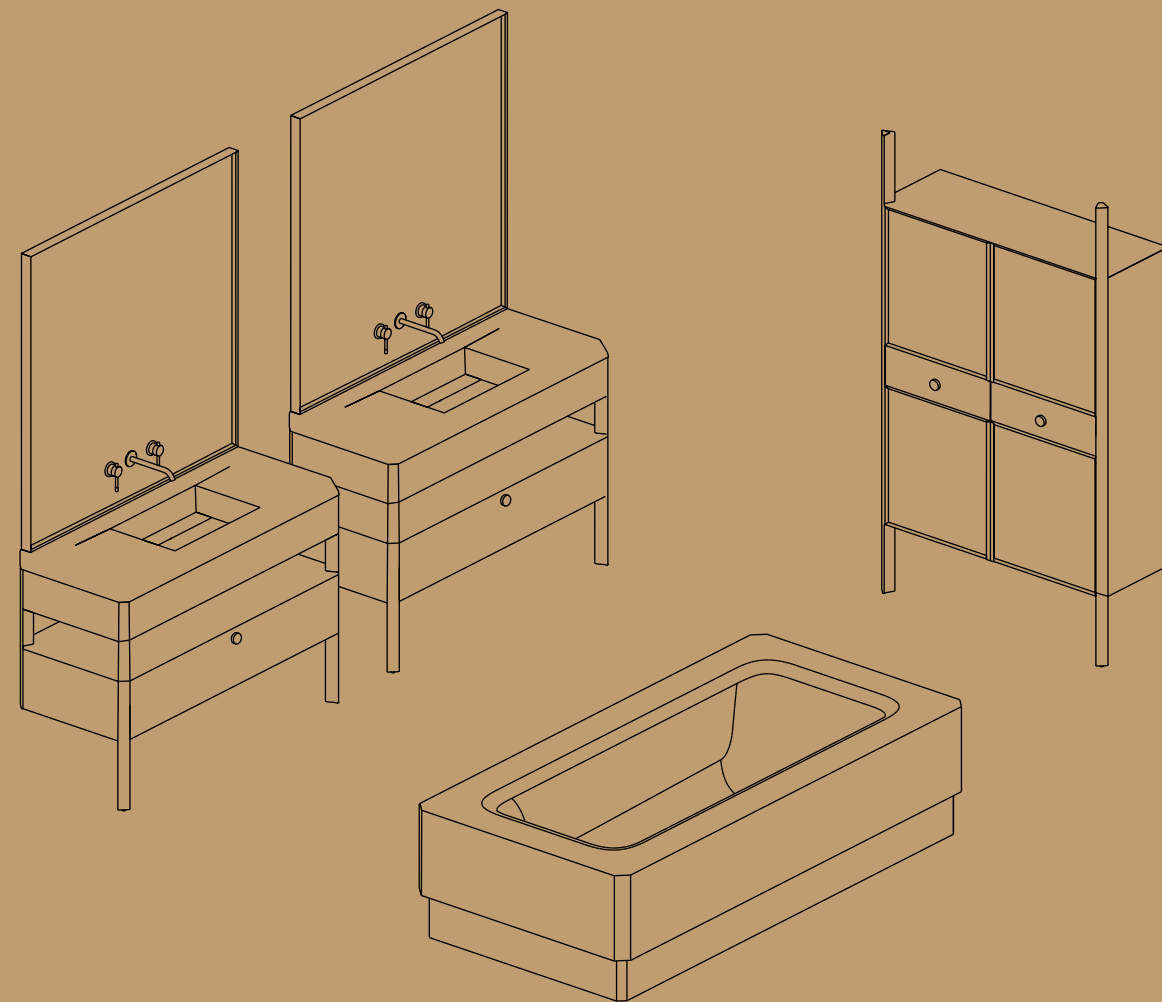

515

1265

→ **Mobile lavabo/Composition with washbasin units/Composition avec éléments sous-vasque**
 Laccato opaco 20 Blu Notte
 20 Blu Notte matt lacquered
 Laqué mat 20 Blu Notte
 → **Piano lavabo/Top with integrated basin/Plan de toilette avec vasque moulée**
 Solysand

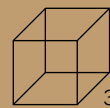

365

1065

→ **Colonne/Hanging full-height units/Colonne**
 Laccato opaco 20 Blu Notte/Cristallo Sun
 20 Blu Notte matt lacquered/Sun glass
 Laqué mat 20 Blu Notte/Verre Sun

Elementi/Elements → Vasca/Bathtub/Baignoire
Éléments Relax





- IT** I componenti metallic lateral sono elementi estetici dalla forte personalità che donano particolare eleganza alla composizione.
- EN** The metallic lateral components are aesthetic elements with strong personality that give particular elegance to the composition.
- FR** Les composants métalliques latéraux sont des éléments esthétiques à forte personnalité qui apportent une élégance particulière à la composition.



- IT** La variante anta telaio permette di inserire all'interno materiali diversi per creare abbinamenti sempre nuovi e altamente personalizzati.
- EN** The frame door variant makes it possible to insert different materials inside, to create always new and highly customised combinations.
- FR** La variante porte-cadre permet d'y insérer des matériaux différents afin de créer des combinaisons toujours nouvelles et hautement personnalisées.



Una nuova relazione libera e fisica tra spazio, arredi,
persone e benessere.

INTRAMONTABILE ELEGANZA

EN TIMELESS ELEGANCE
A new free and physical
relationship between space,
furnishings, people
and well-being.

FR ÉLÉGANCE INTEMPORELLE
Une nouvelle relation libre
et physique entre l'espace,
les meubles, les personnes
et le bien-être.

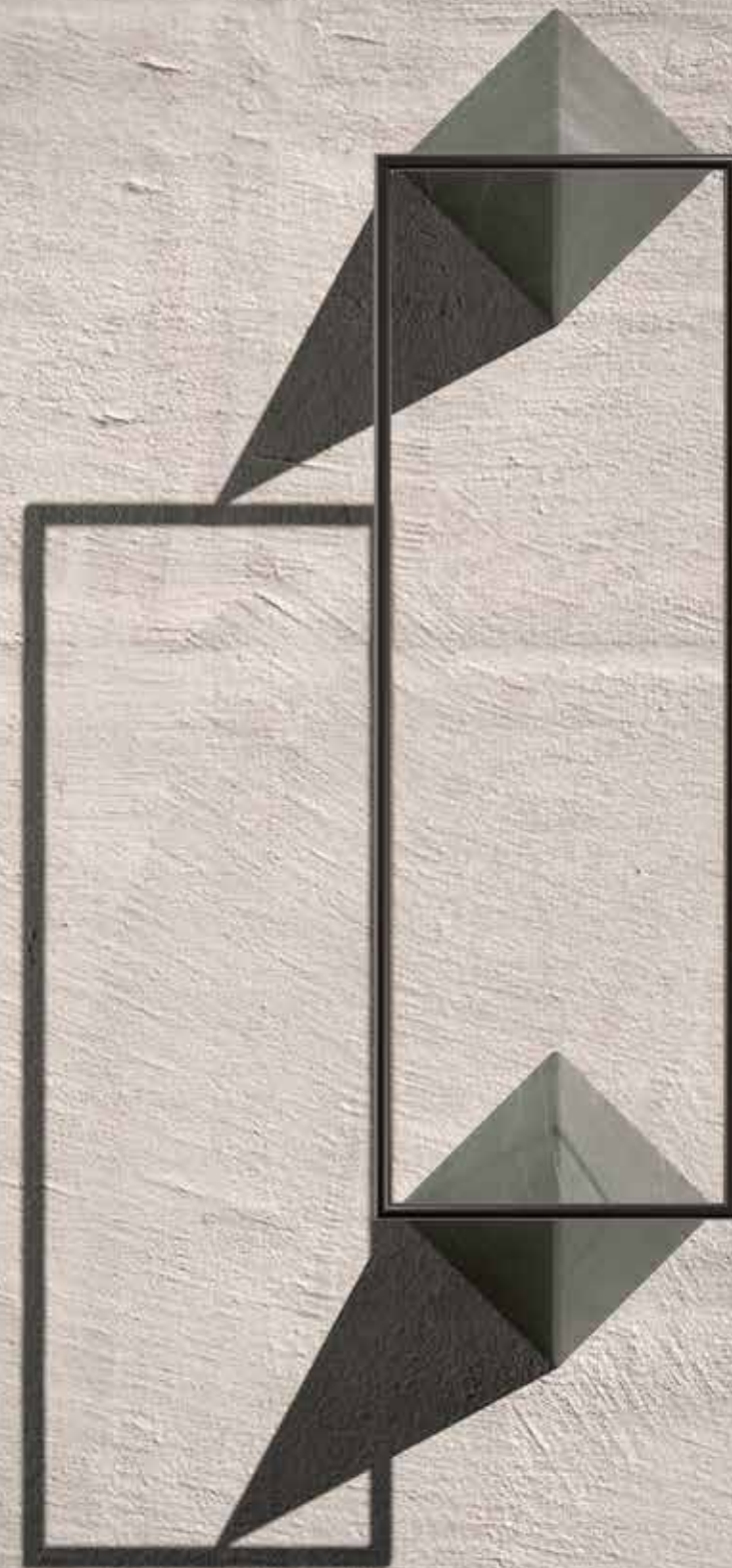



N. 5

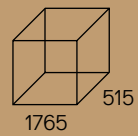
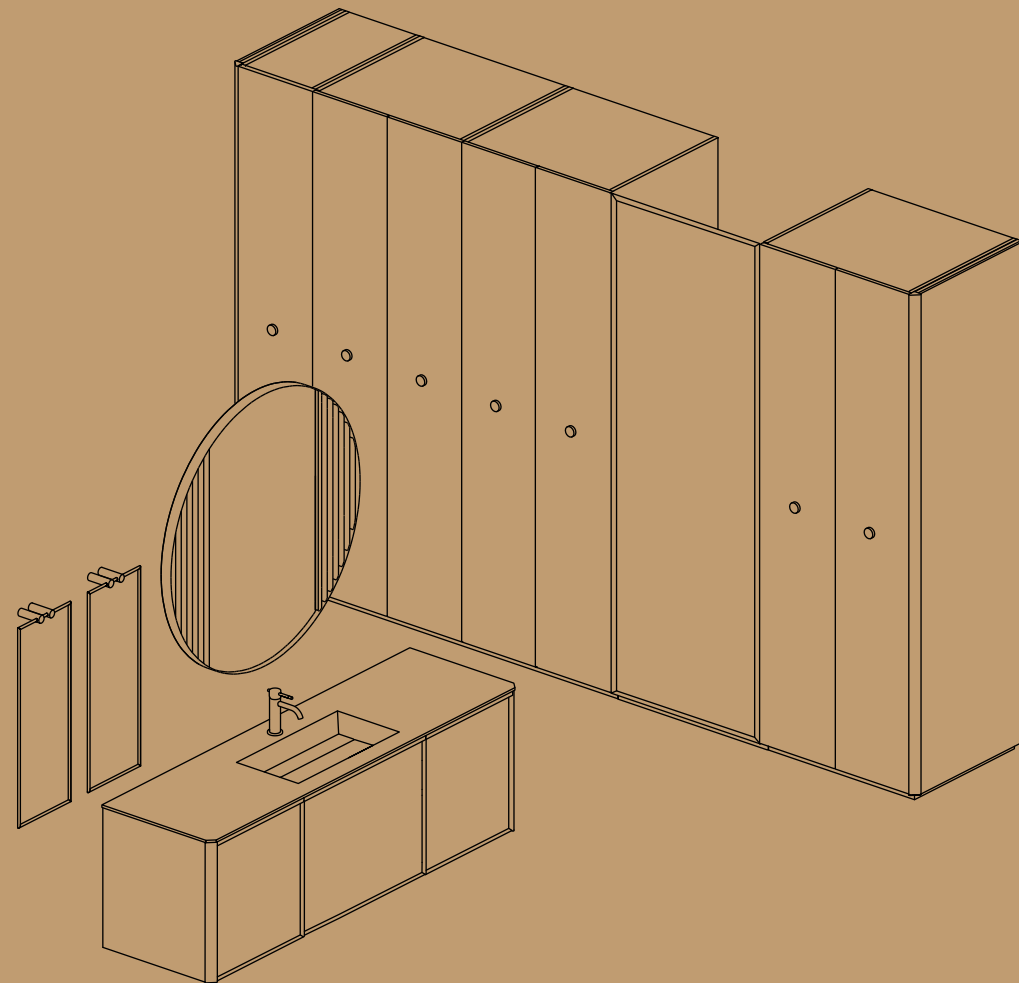

515

1765

→ **Mobile lavabo/Composition with washbasin units/Composition avec éléments sous-vasque**

Laminam Pietra Grey/
Impiallacciato Noce Canaletto 3D
Laminam Pietra Grey/
Noce Canaletto veneered 3D
Laminam Pietra Grey/
Plaqué Noce Canaletto 3D

→ **Piano lavabo/Top with integrated basin/Plan de toilette avec vasque moulée**
Laminam Pietra Grey

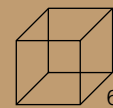

625

3215

→ **Colonne/Hanging full-height units/Colonne**

Laccato opaco 33 Nichel
33 Nichel matt lacquered
Laqué mat 33 Nichel

Elementi/Elements
Éléments

→ **Portasciugamano/Towel Holder/Porte-serviettes**
Line

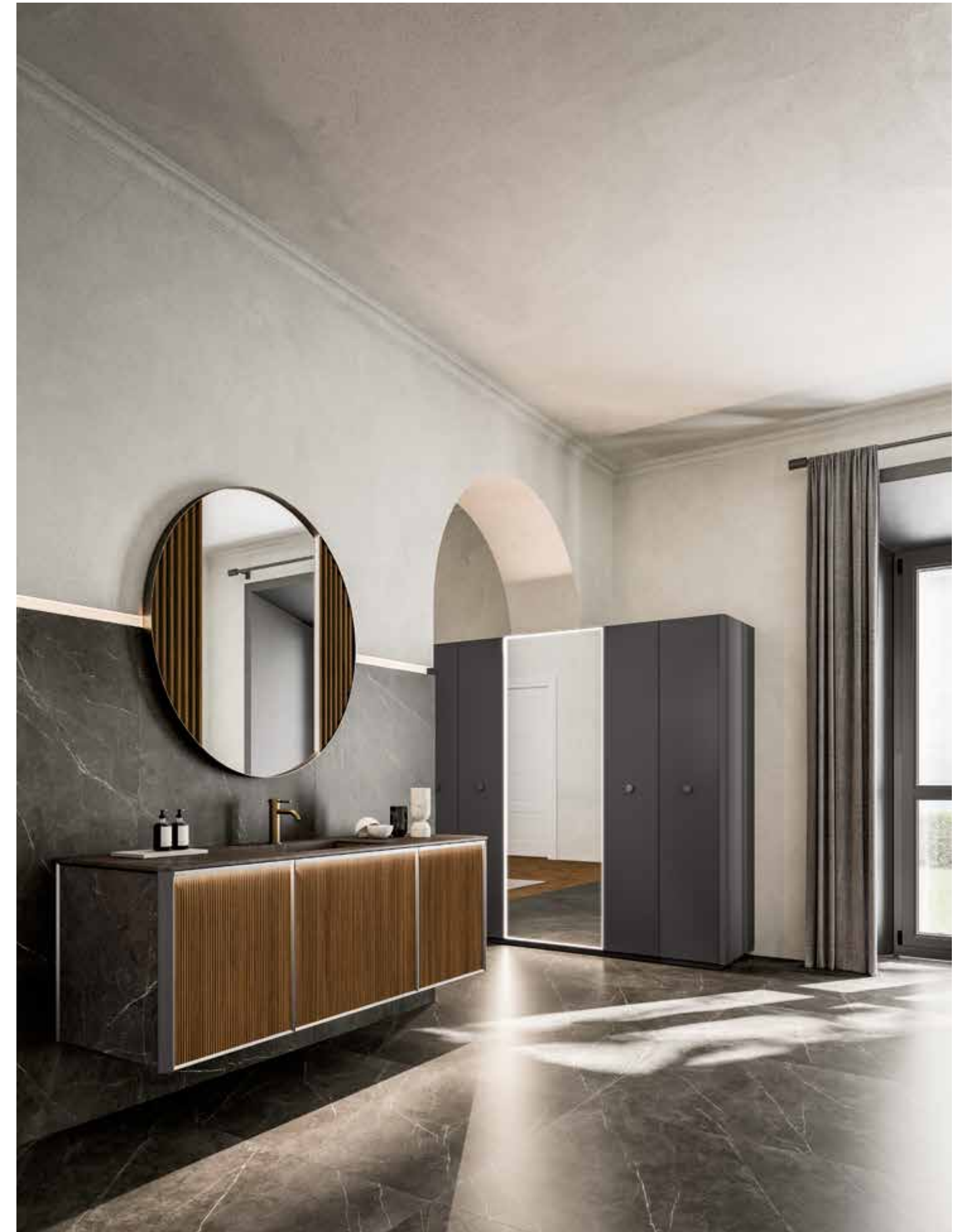



- IT** I fianchi del mobile possono essere impreziositi con la variante telaio per inserire diversi tipi di finiture, donando così alla composizione interpretazioni diverse e mai scontate.
- EN** The sides of the cabinet can be embellished with the frame variant to insert different types of finishes, thus giving the composition different interpretations that are never predictable.
- FR** Les flancs du meuble peuvent être embellis par la variante cadre qui permet d'insérer différents types de finitions, conférant ainsi à la composition différentes interprétations, jamais prévisibles.





IT Le svariate tipologie di colonne permettono di creare diverse conformazioni di armadiature a seconda di spazi disponibili e necessità funzionali.

EN The various types of columns make it possible to create different configurations of the cabinet according to available spaces and functional needs.

FR Les divers types de colonnes permettent de créer différentes conformations d'armoires en fonction de l'espace disponible et des besoins fonctionnels.



Geometrie variabili del benessere in cui classico e moderno si fondono con le emozioni dell'arredo.

GEOMETRIE VARIABILI

EN VARIABLE GEOMETRIES
Variable geometries of well-being
in which classic and modern
blend with the emotions
of the furnishings.

FR GÉOMÉTRIE VARIABLE
Géométrie variable du bien-être
où le classique et le moderne
se fondent avec les émotions
de l'ameublement.





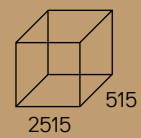
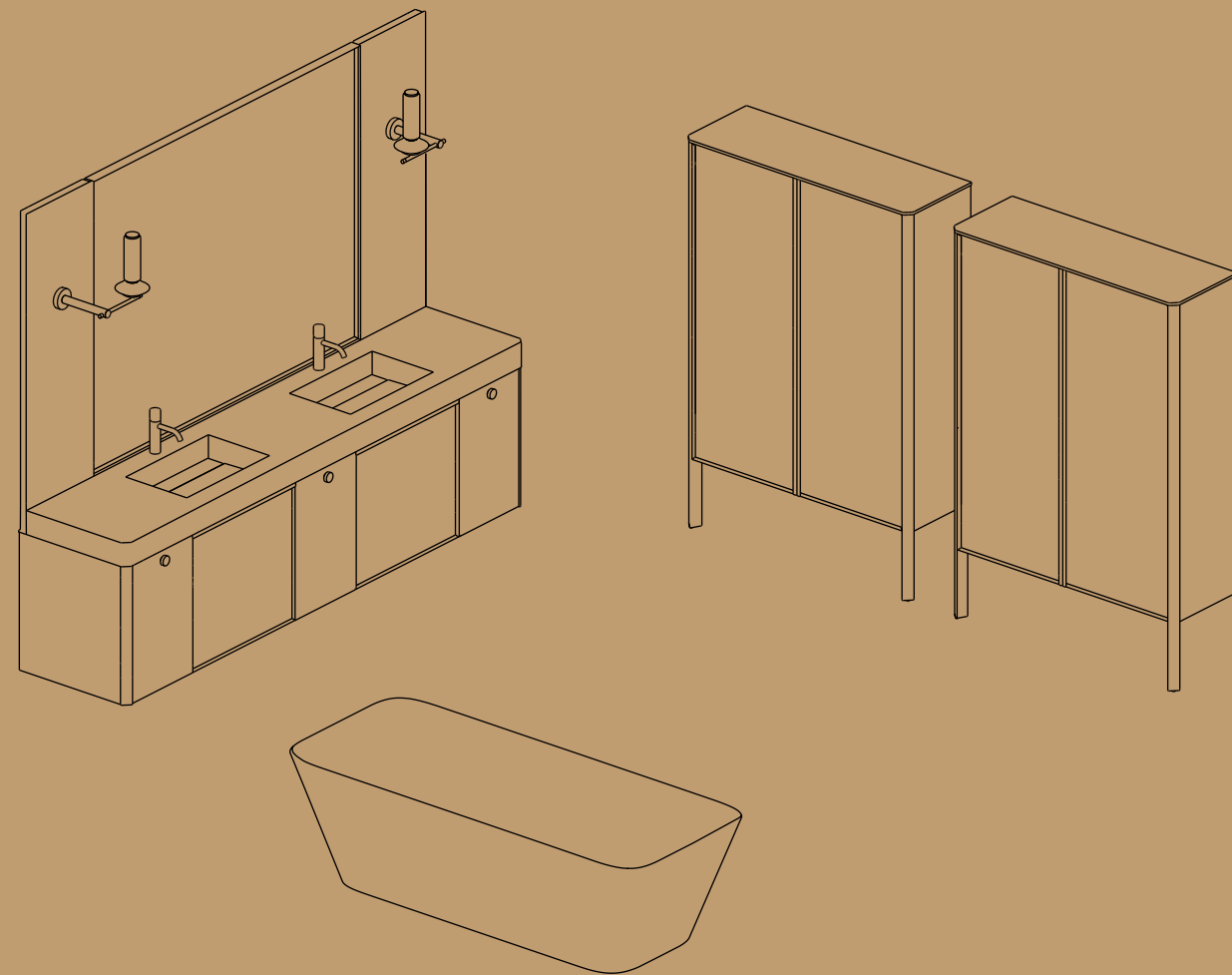

515

2515

→ **Mobile lavabo/Composition with washbasin units/Composition avec éléments sous-vasque**
 Laccato opaco 3D/Lucido 10 Corda
 10 Corda matt effect 3D/glossy lacquered
 Laqué mat avec effet 3D/brillant 10 Corda
 → **Mensolone lavabo/Top in high thickness with integr. basin/Plan de toilette avec grosse épaisseur avec vasque moulée**
 Marmo Emperador Dark
 Emperador Dark marble
 Marbre Emperador Dark

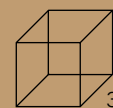

365

1065

→ **Colonne/Hanging full-height units/Colonne**
 Laccato lucido 10 Corda
 Cristallo specchiante/
 10 Corda glossy lacquered
 Reflective glass/
 Laqué brillant 10 Corda
 Verre réfléchissant

Elementi/Elements → Vasca/Bathtub/Baignoire
Éléments → Style

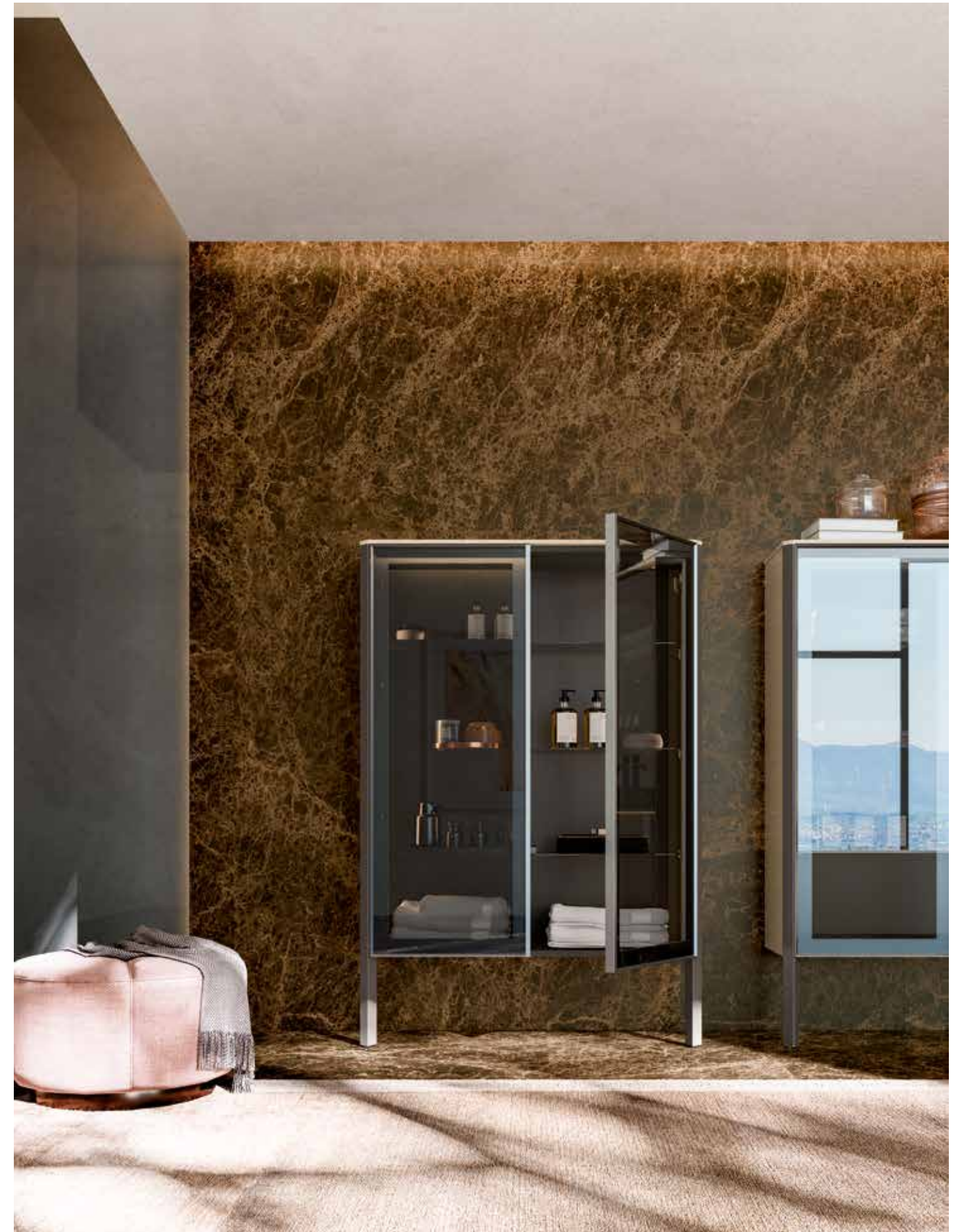



- IT** Il marmo, come materiale alternativo nell'utilizzo dei top, anche con vasca integrata, arricchisce la composizione rendendola elegante e glamour.
- EN** The marbles, as an alternative material in the use of the tops, also with integrated basin, enrich the composition, making it elegant and glamorous.
- FR** Le marbre, comme matériau alternatif pour l'utilisation des surfaces, avec possibilité de vasque moulée, enrichit la composition en la rendant élégante et en lui conférant une touche glamour.



- IT** Il bagno padronale con doppia vasca: tutto è proporzionato e coordinato.
La finitura Nichel che caratterizza tutte le parti metalliche, è la tinta perfetta da abbinare a qualsiasi colore.
- EN** The master bathroom with double basin: everything is proportioned and coordinated.
The Nickel finish that characterises all the metal parts is the perfect shade to combine with any colour.
- FR** La salle de bain principale avec sa baignoire double : tout en proportions et en coordination.
Les finitions Nichel qui caractérisent toutes les parties métalliques, représentent la teinte idéale à combiner à toute autre couleur.



Inedite opportunità progettuali si fondono in materiali e design per unioni esclusive.

SINTONIE MATERICHE

EN HARMONY OF MATERIALS
Innovative design opportunities
merge into materials and designs
for exclusive unions.

FR HARMONIE MATÉRIELLE
Des opportunités conceptuelles
inédites se fondent en matériaux
et design pour des unions
exclusives.

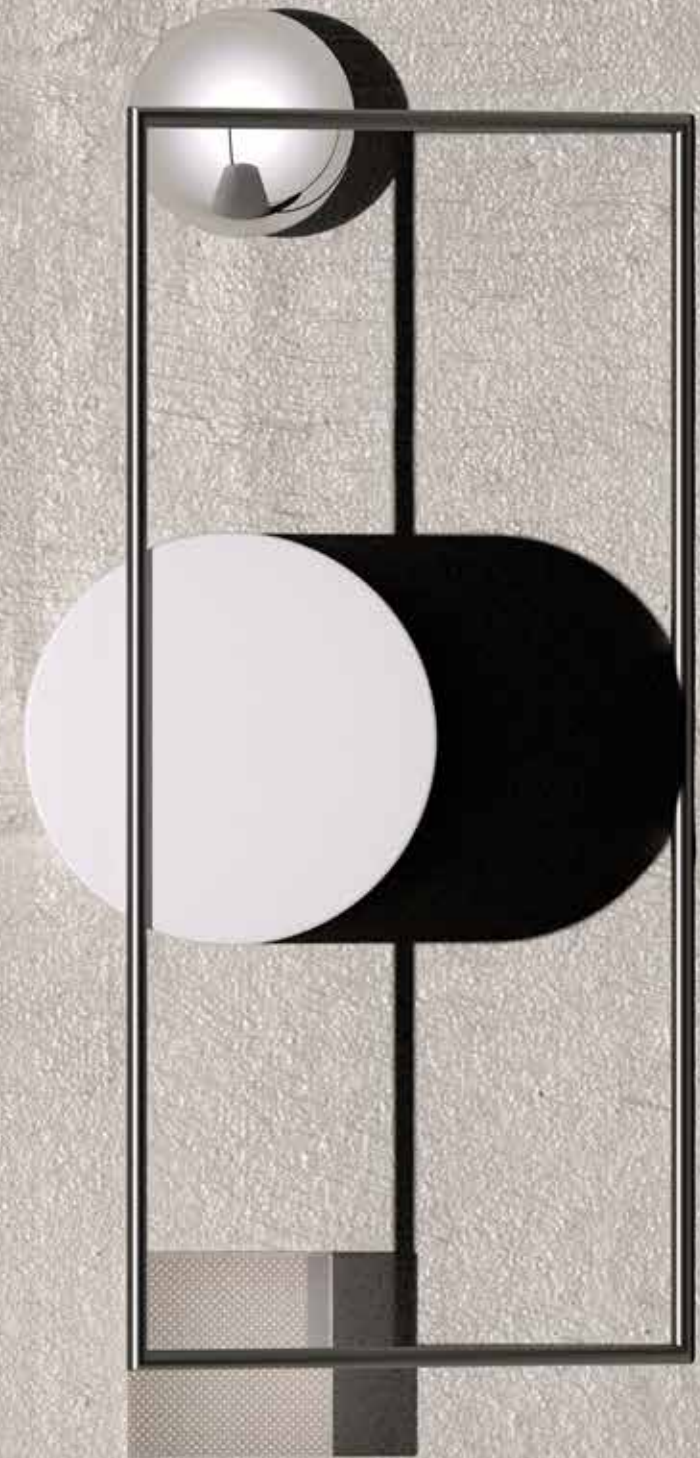



N. 7

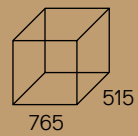
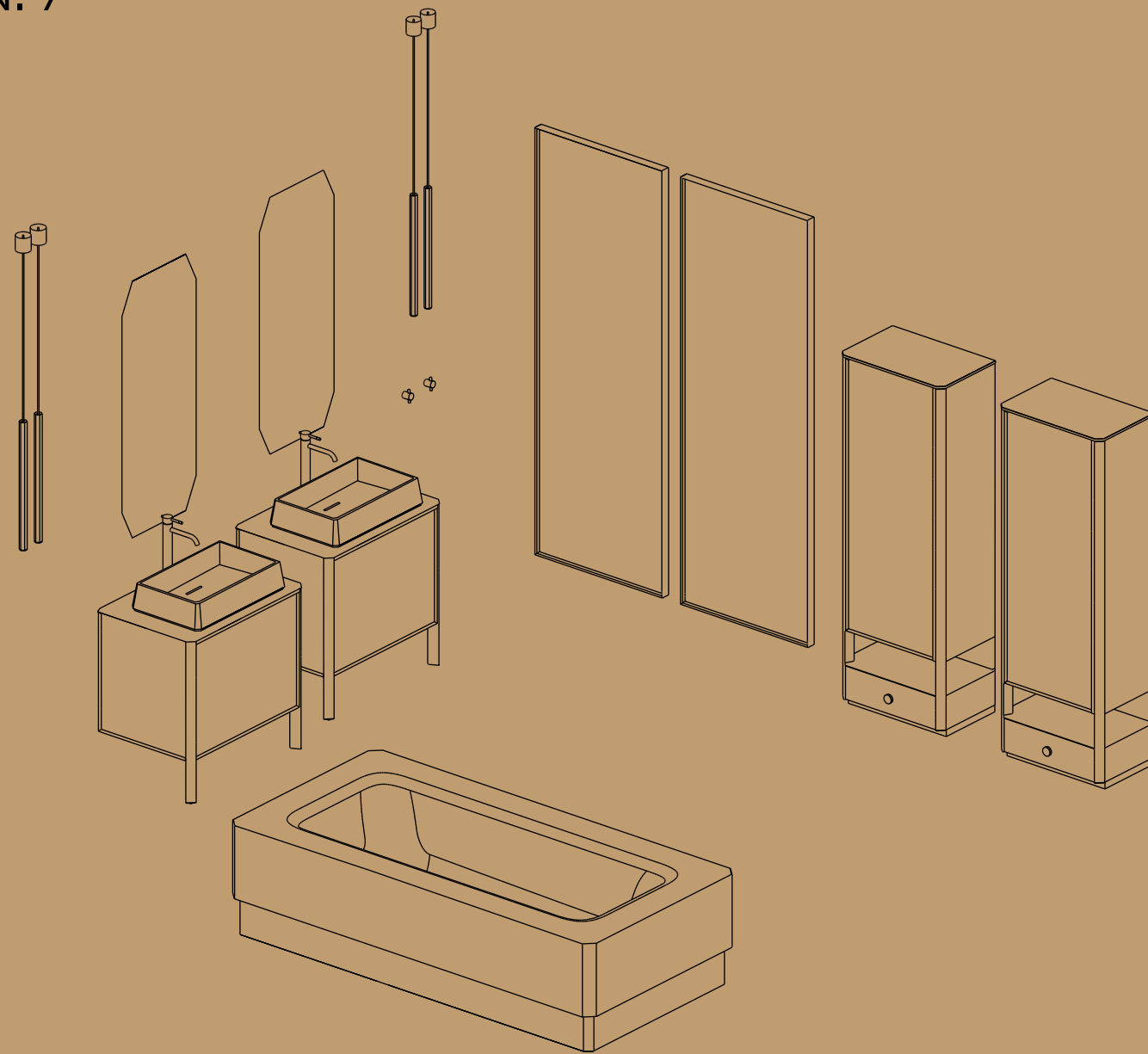

- **Mobile lavabo/Composition with washbasin units/Composition avec éléments sous-vasque**
 Cristallo Sun
 Sun glass
 Verre Sun
- **Piano/Top/Plan de toilette**
 Cristallo Sun
 Sun glass
 Verre Sun

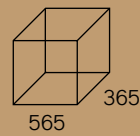

- **Colonne/Hanging full-height units/Colonne**
 Laccato opaco 33 Nichel/Cristallo Sun
 33 Nichel matt lacquered/Sun glass
 Laqué mat 33 Nichel/Verre Sun

Elementi/Elements
Éléments

- | | | |
|-------------------------------------|--------------------------------------|------------------------------------|
| → Vasca/Bathtub/Baignoire
Relax | → Lampade/Lamps/Lampes
Vertical | → Appendini/Hooks/Patères
Comma |
| → Lavabo/ Basin/ Vasque
Lingotto | → Specchi/Mirrors/Miroirs
Picture | |

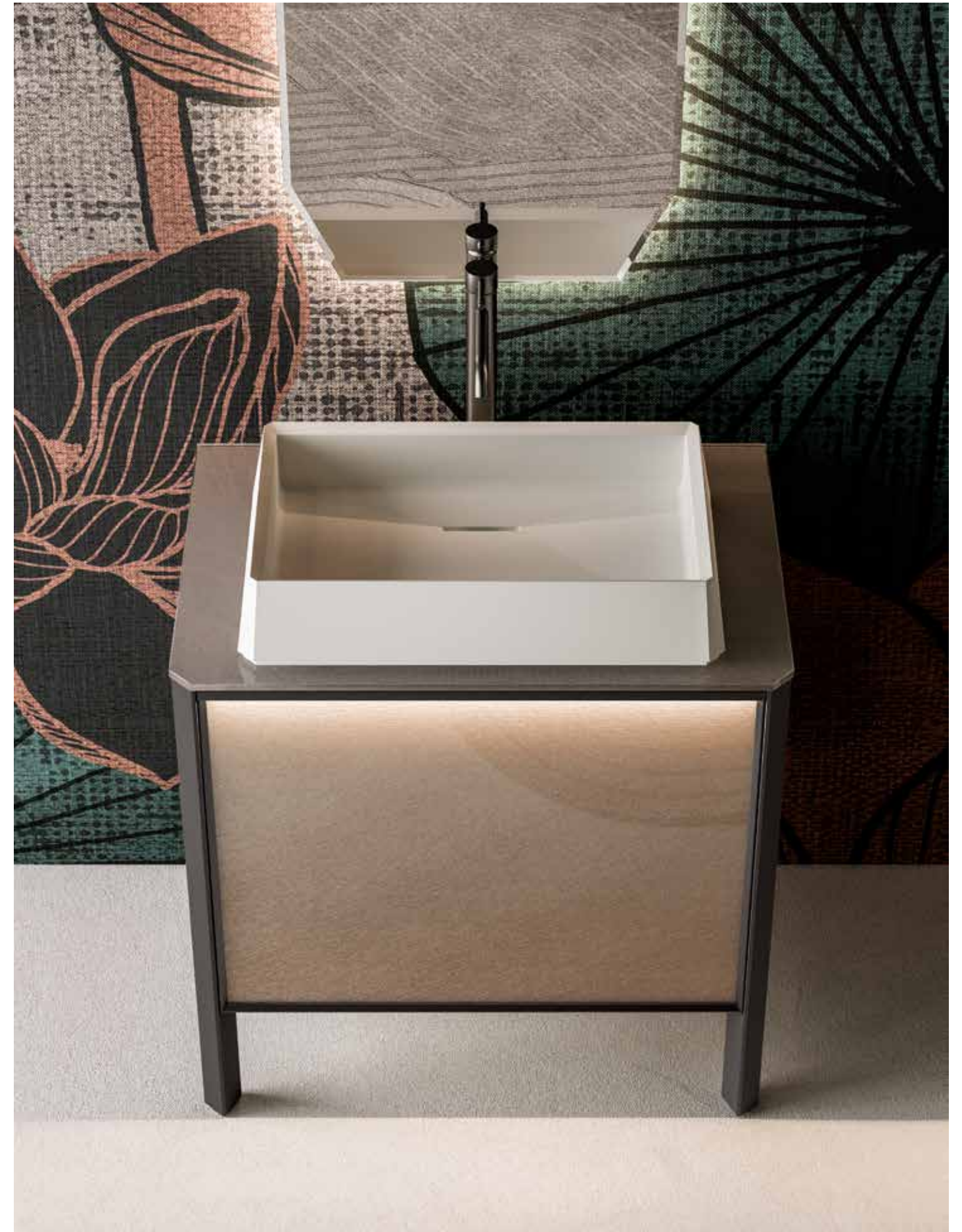





- IT** Il particolare telaio con apposita impugnatura per un'agevole apertura può, su richiesta, alloggiare una luce che ne esalta i materiali inseriti.
- EN** On request, the particular frame with a special handle for ease of opening can house a light that enhances the inserted materials.
- FR** Le cadre particulier avec sa poignée pour une ouverture aisée peut, sur demande, accueillir un éclairage mettant en évidence les matériaux insérés.

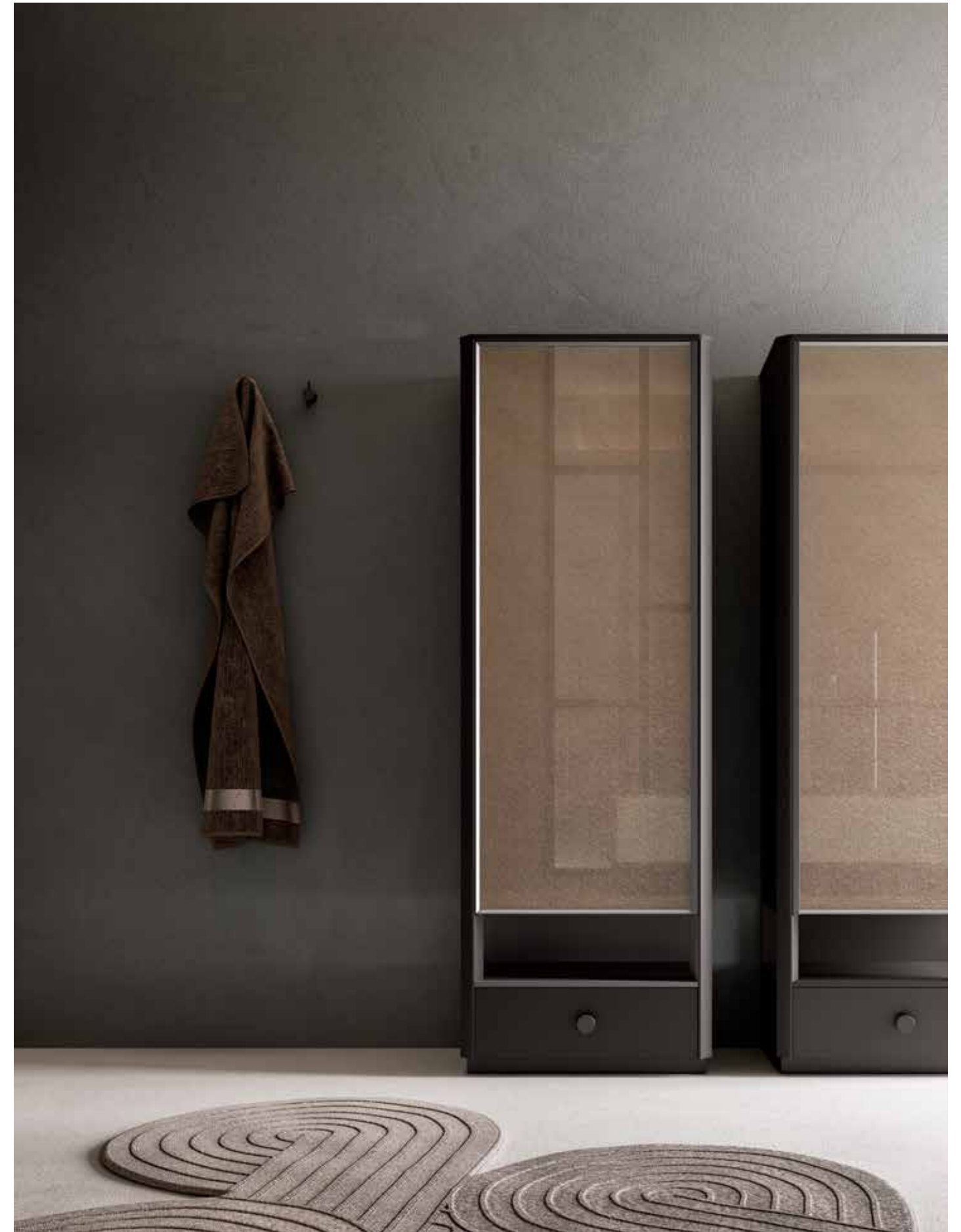

Razionale semplicità armonica in cui la bellezza
e lo spazio rinascono nella luce.

BAGLIORI ESTETICI

EN AESTHETIC GLOW
Rational harmonic simplicity
in which beauty and space
are born again in light.

FR ÉCLATS ESTHÉTIQUES
La simplicité harmonique
et rationnelle qui font renaître
la beauté et l'espace dans
la lumière.

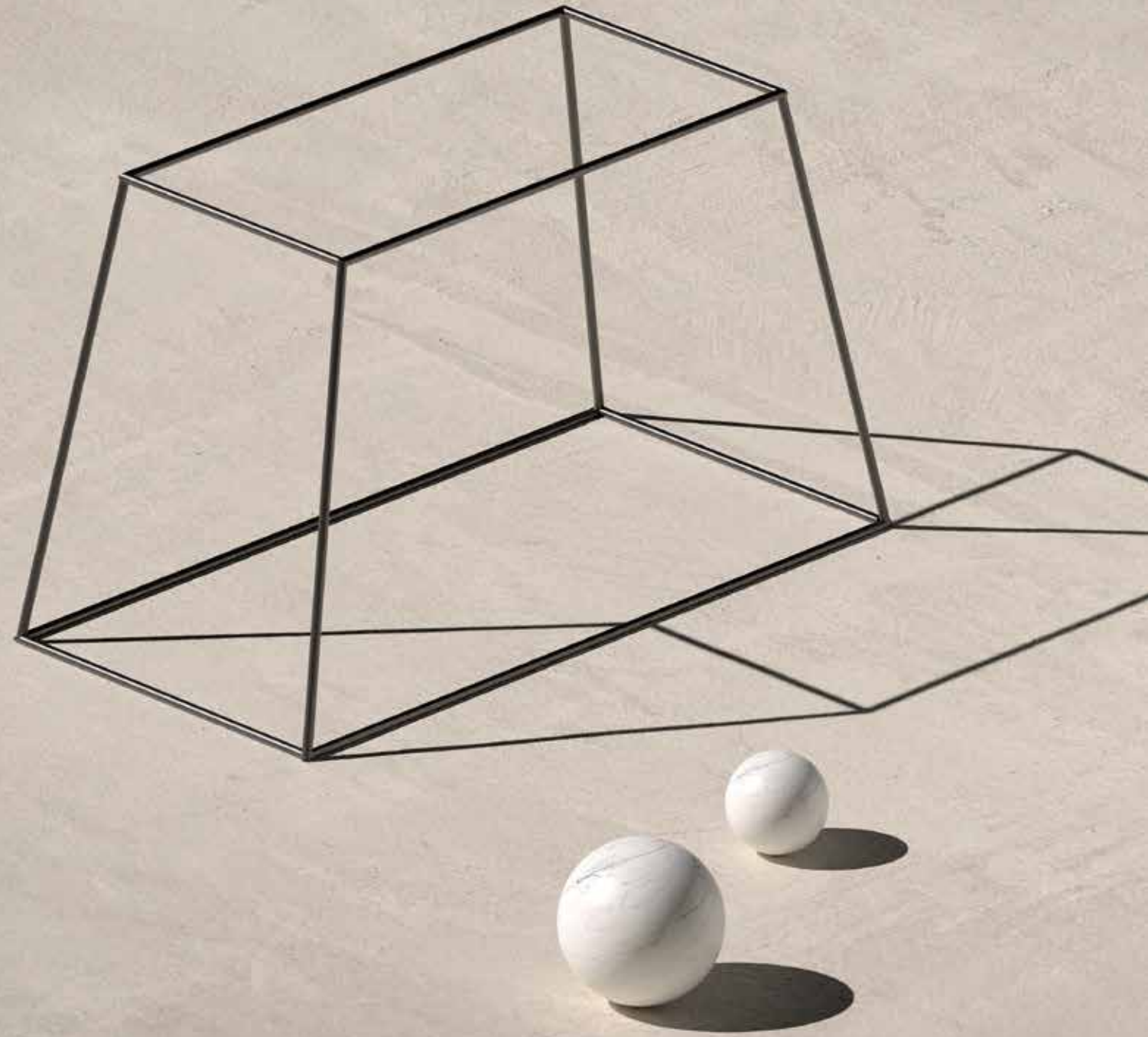



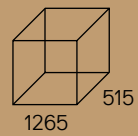
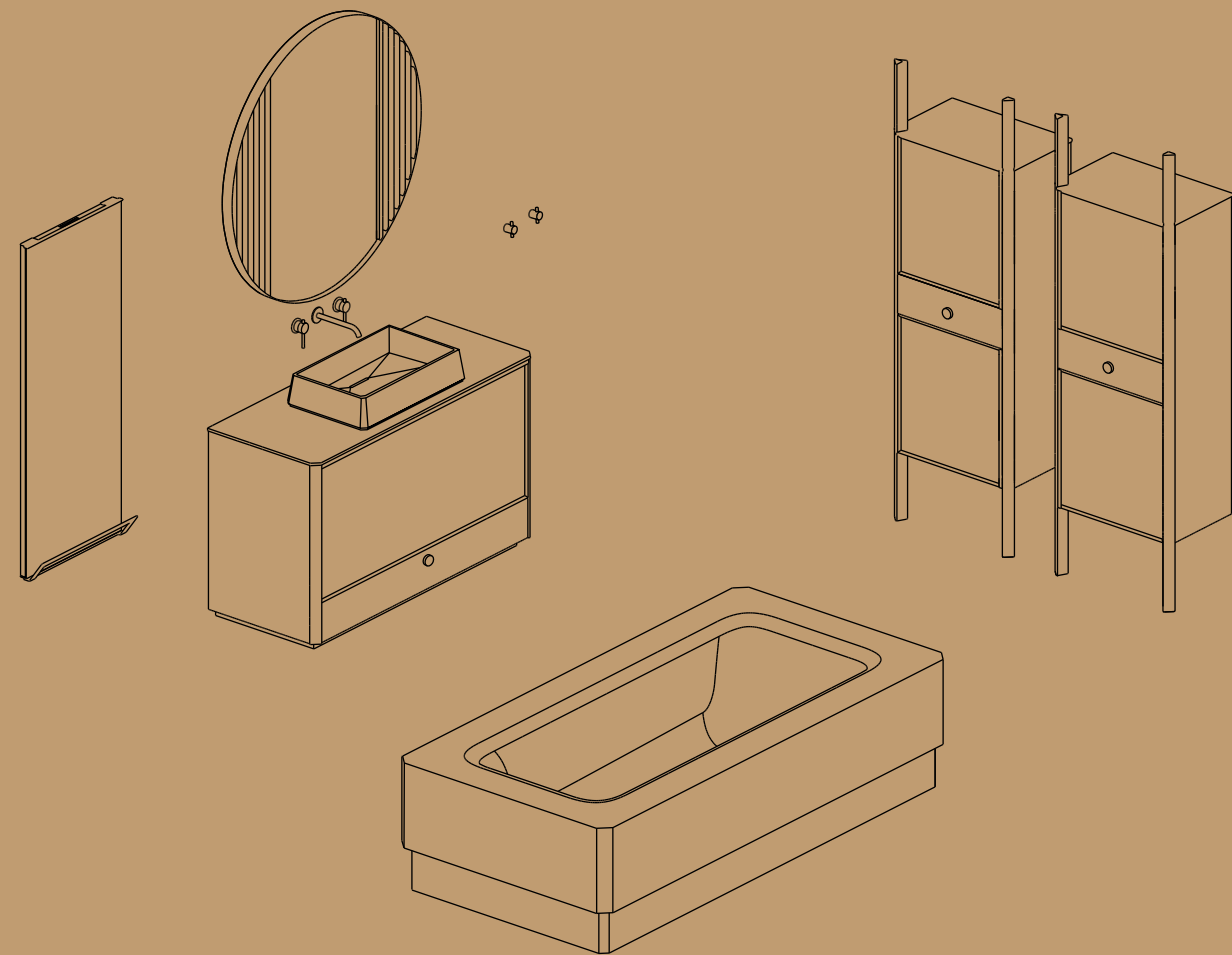

515

1265

- **Mobile lavabo/Composition with washbasin units/Composition avec éléments sous-vasque**
 Laminam Statuarietto/
 Laccato opaco 01 Ghiaccio 3D
 Laminam Statuarietto/
 01 Ghiaccio matt 3D effect lacquered
 Laminam Statuarietto/
 Laqué mat 3D effet 01 Ghiaccio
 → **Piano/Top/Plan de toilette**
 Laminam Statuarietto

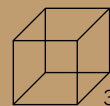

365

565

- **Colonne/Hanging full-height units/Colonne**
 Laminam Statuarietto/
 Laccato opaco 33 Nichel 3D
 Laminam Statuarietto/
 33 Nichel matt 3D effect lacquered
 Laminam Statuarietto/
 Laqué mat 3D effet 33 Nichel

Elementi/Elements
Éléments

- Vasca/Bathtub/Baignoire Relax
 → Lavabo/Basin/Vasque Lingotto

- Termoarredo/Heated towel racks/Radiateur décoratif Frame

- Appendini/Hooks/Patères Comma

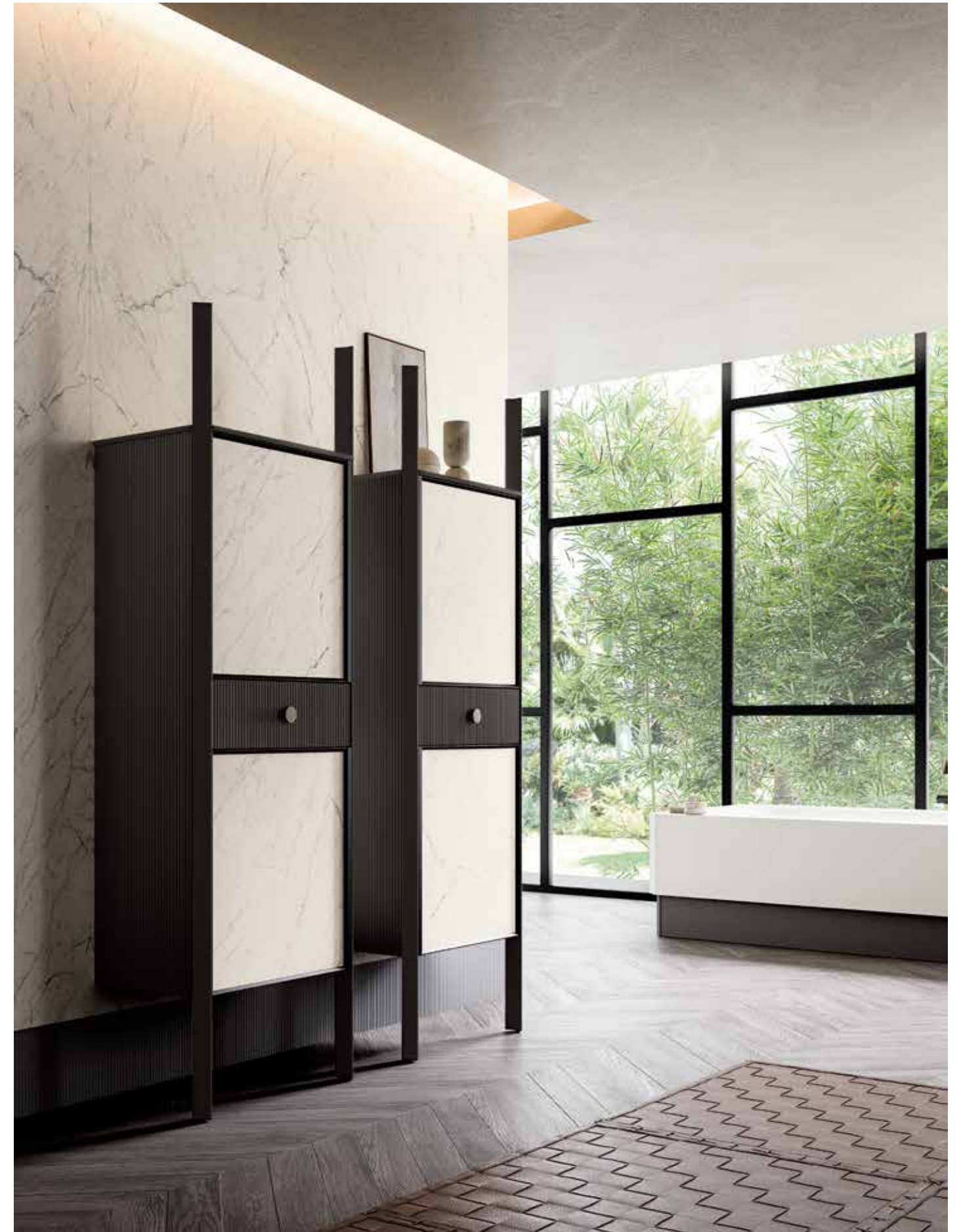



IT I particolari appendini Comma completano l'offerta d'arredo della sala da bagno.
EN The particular wall hooks Comma complete the bathroom furnishing offer.
FR Les patères au mur particuliers Comma complètent l'offre d'ameublement de la salle de bain.



IT Il lavabo da appoggio Lingotto è frutto di un attento studio, dove proporzioni, necessità contenitive ed estetica si uniscono per offrire un progetto unico e distintivo.
EN The Lingotto standing basin is the result of a careful study, where proportions, storage needs and aesthetics unite to offer a unique and distinctive design.
FR Le vasque à poser Lingotto est le fruit d'une recherche attentive, qui unit proportions, capacités de contenu et esthétique en offrant un projet unique et distinctif.



Aria e luce, pieni e vuoti, materiali e colori definiscono l'esperienza del design.

EQUILIBRIO DI PROPORZIONI

EN BALANCE
OF PROPORTIONS
Air and light, full and empty
spaces, materials and colours
define the experience
of the design.

FR ÉQUILIBRE
DES PROPORTIONS
Air et lumière, remplissages
et vides, matériaux et couleurs,
définissent l'expérience
du design.





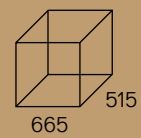
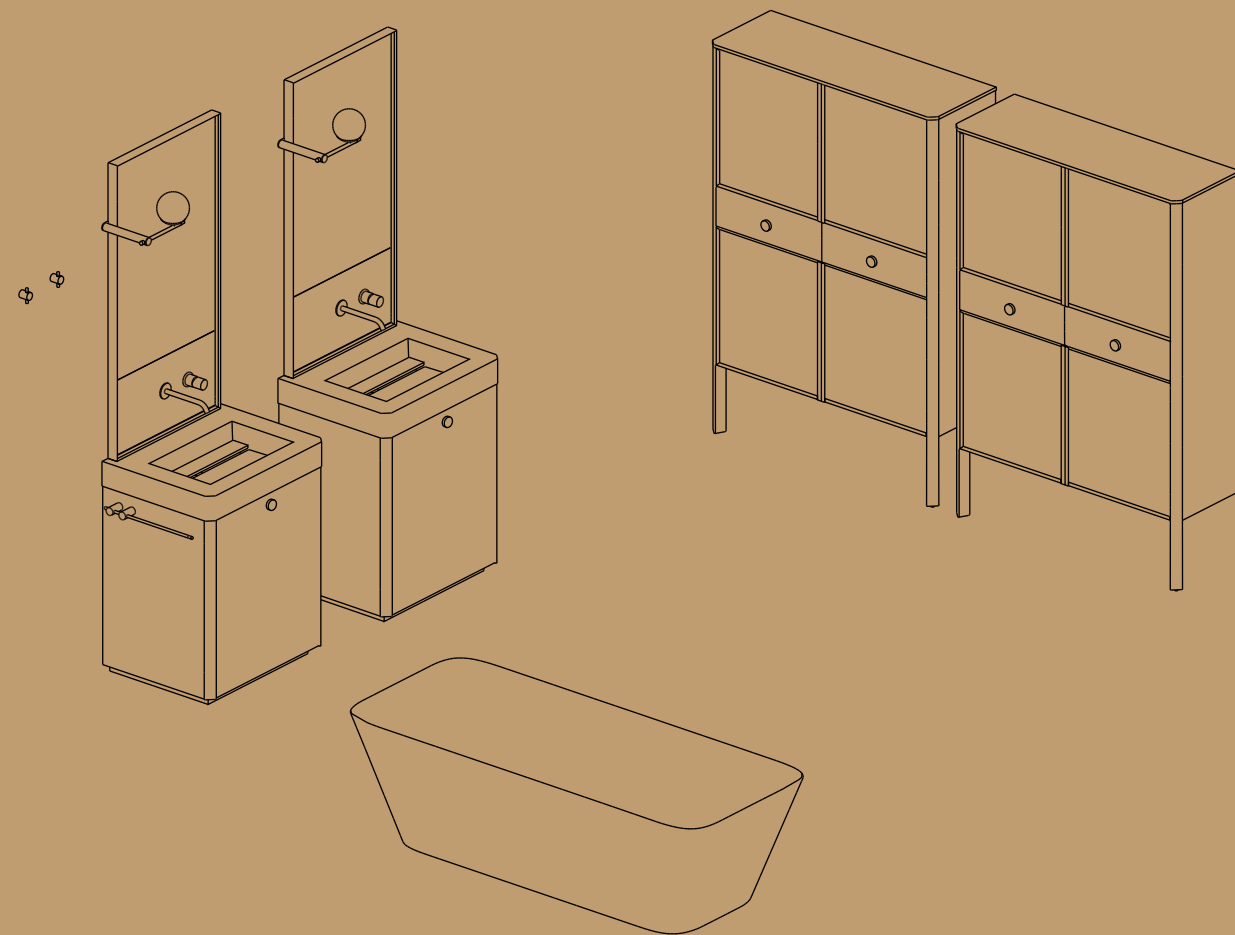

665 515

→ **Mobile lavabo/Composition with washbasin units/Composition avec éléments sous-vasque**
 Laccato 32 Metallizzato Oro Rosa
 32 Metallizzato Oro Rosa lacquered
 Laqué 32 Metallizzato Oro Rosa
 → **Mensolone lavabo/Top in high thickness with integr. basin/Plan de toilette avec grosse épaisseur avec vasque moulée**
 Laminam Noir Desir opaco

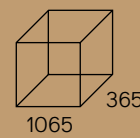

1065 365

→ **Colonne/Hanging full-height units/Colonne**
 Laccato 32 Metallizzato Oro Rosa/
 Cristallo specchiante
 32 Metallizzato Oro Rosa lacquered/
 Reflective glass
 Laqué 32 Metallizzato Oro Rosa/
 Verre réfléchissant

Elementi/Elements → Vasca/Bathtub/Baignoire
Éléments Style
 → Appendini/Hooks/Patères
 Comma

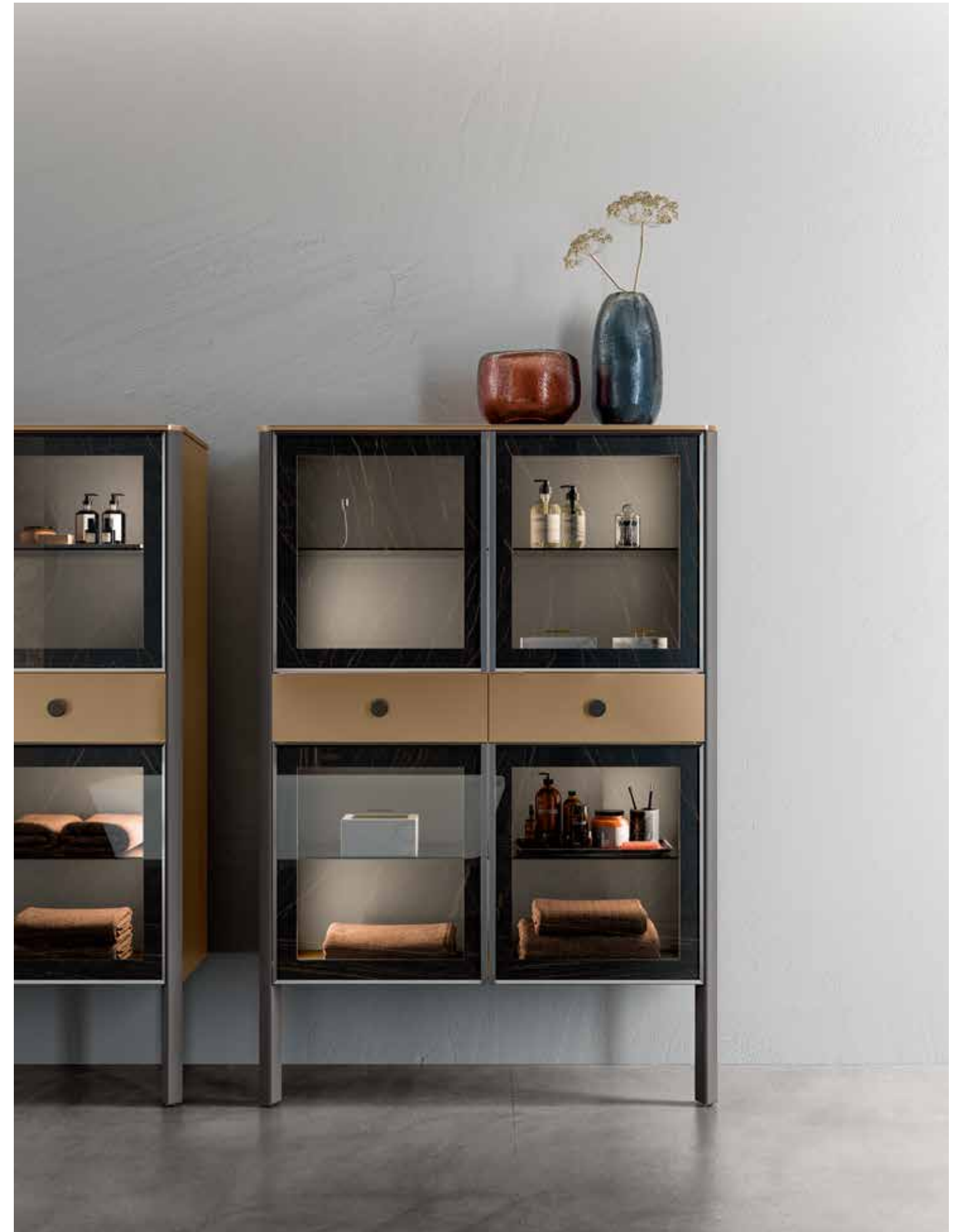



IT Il particolare specchio illuminato, dal disegno esclusivo Cerasa, può essere realizzato nella versione con telaio solo specchio, oppure arricchito con vari materiali.
EN The particular illuminated mirror, with the exclusive Cerasa design, can be made in the version with frame only mirror, or enriched with various materials.
FR Le miroir éclairé au design exclusif par Cerasa peut être réalisé dans sa version avec cadre, miroir uniquement ou enrichi de matériaux divers.



IT In alternativa ai portasciugamani d'arredo a parete, sono disponibili quelli per fianco: accessori pratici e funzionali dalle forme accattivanti e particolari.

EN As an alternative to wall-mounted towel holders, ones for the side are available: practical and functional accessories with captivating and distinctive shapes.

FR Comme alternative aux porte-serviette au mur, nous vous proposons ceux qui s'accrochent au flancs des meubles : des accessoires pratiques et fonctionnels aux formes captivantes et originales.

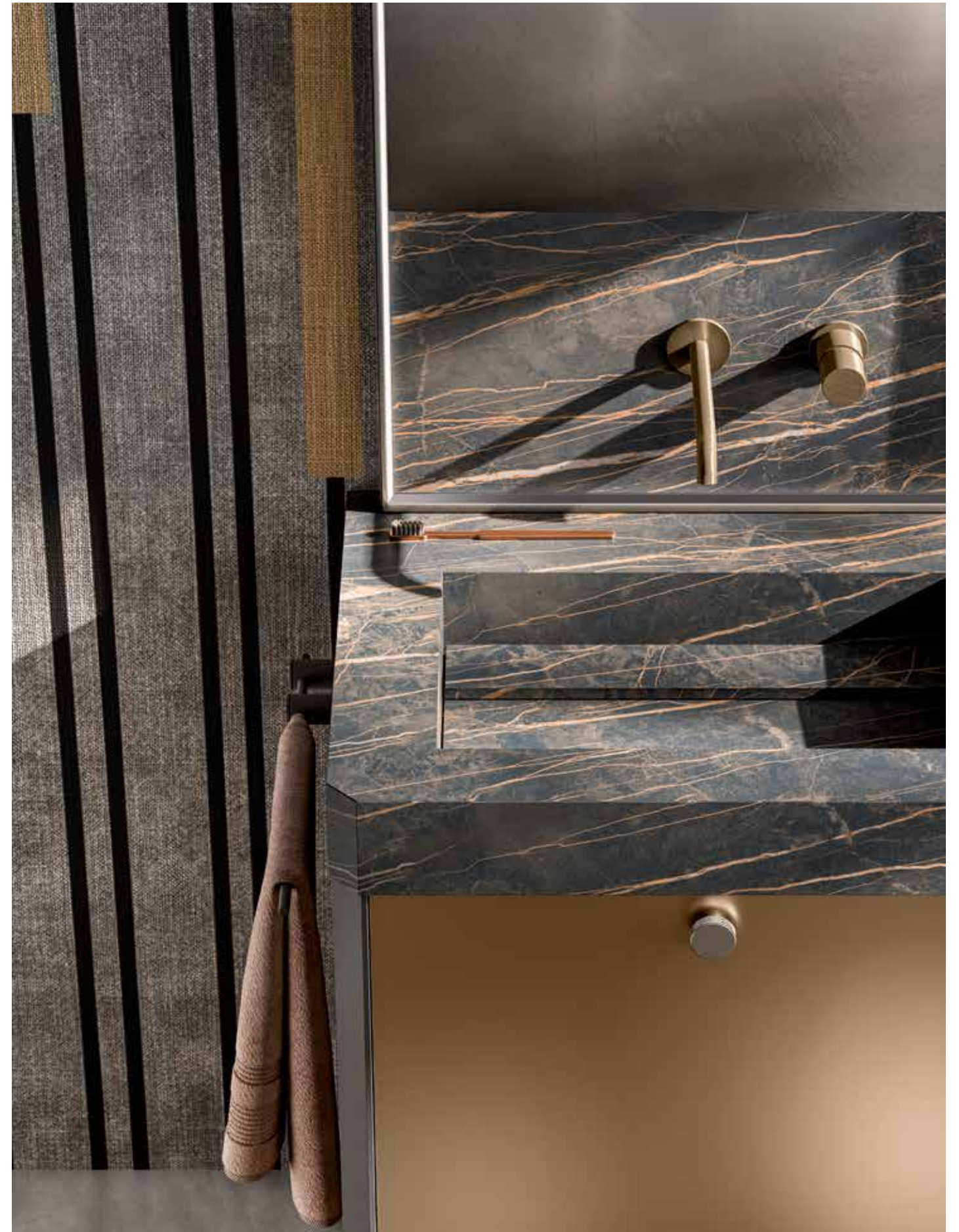

Gli arredi si fanno composizione poetica, esperienza visiva e tattile in una nuova iconografia delle forme.

POETICA DELLO SPAZIO

EN POETICS OF SPACE
The furnishings create
a poetic composition, a visual
and tactile experience in a new
iconography of forms.

FR POÉSIE DE L'ESPACE
Les meubles deviennent
composition poétique,
expérience visuelle et tactile
en une nouvelle iconographie
des formes.





N. 10

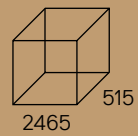
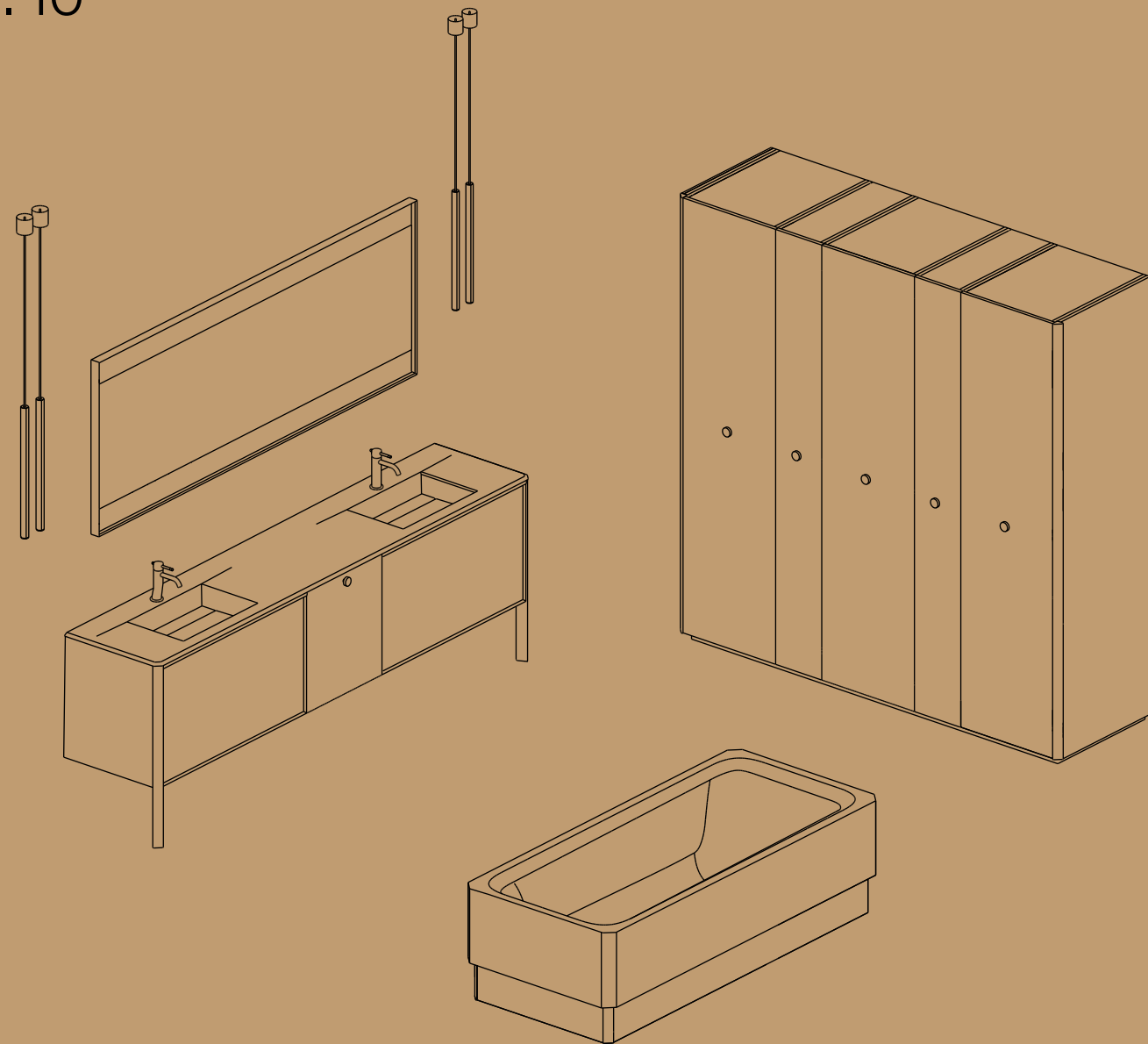

→ **Mobile lavabo/Composition with washbasin units/Composition avec éléments sous-vasquew**
Laccato opaco 12 Fango 3D
Cristallo specchiante/
12 Fango matt 3D effect lacquered
Reflective glass/
Laqué mat effet 3D 12 Fango
Verre réfléchissant

→ **Piano lavabo/Top with integrated basin/Plan de toilette avec vasque moulée**
Solysand

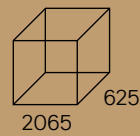

→ **Colonne/Hanging full-height units/Colonne**
Laccato opaco 12 Fango liscio/3D
Smooth and 3D effect matt 12 Fango
lacquered/Laqué 12 Fango mat lisse et avec effet 3D

Elementi/Elements
Éléments

- Vasca/Bathtub/Baignoire Relax
- Lampade/Lamps/Lampes Vertical





- IT** Le luci da soffitto Vertical uniscono la valenza funzionale a quella estetica creando ambienti dall'atmosfera raffinata ed elegante.
- EN** The Vertical ceiling lights combine functional and aesthetic value, creating a refined and elegant atmosphere.
- FR** L'éclairage de plafond Vertical réunit les valeurs fonctionnelle et esthétique créant des espaces à l'atmosphère raffinée et élégante.





IT I particolari contenitori in legno tinta Nichel, inseriti nei cassetti ed utilizzabili anche esternamente, organizzano funzionalmente gli spazi mantenendo il massimo ordine.
EN The special containers in Nickel-stained wood, inserted in the drawers and usable also externally, functionally organise the spaces, maintaining perfect order.
FR Les récipients particuliers en bois de teinte Nichel, intégrés dans les tiroirs ou à usage externe, permettent une organisation fonctionnelle des espaces afin de maintenir un ordre parfait.

Il fascino del legno e del marmo uniti alla leggerezza dei metalli generano un'oasi di raffinatezza.

CONFINI FLUIDI

EN FLUID BOUNDARIES
The charm of wood and marble
combined with the lightness
of metals create an oasis
of refinement.

FR LIMITES FLUIDES
La fascination du bois
et du marbre unis à la légèreté
des métaux donnent naissance
à un oasis de raffinement.

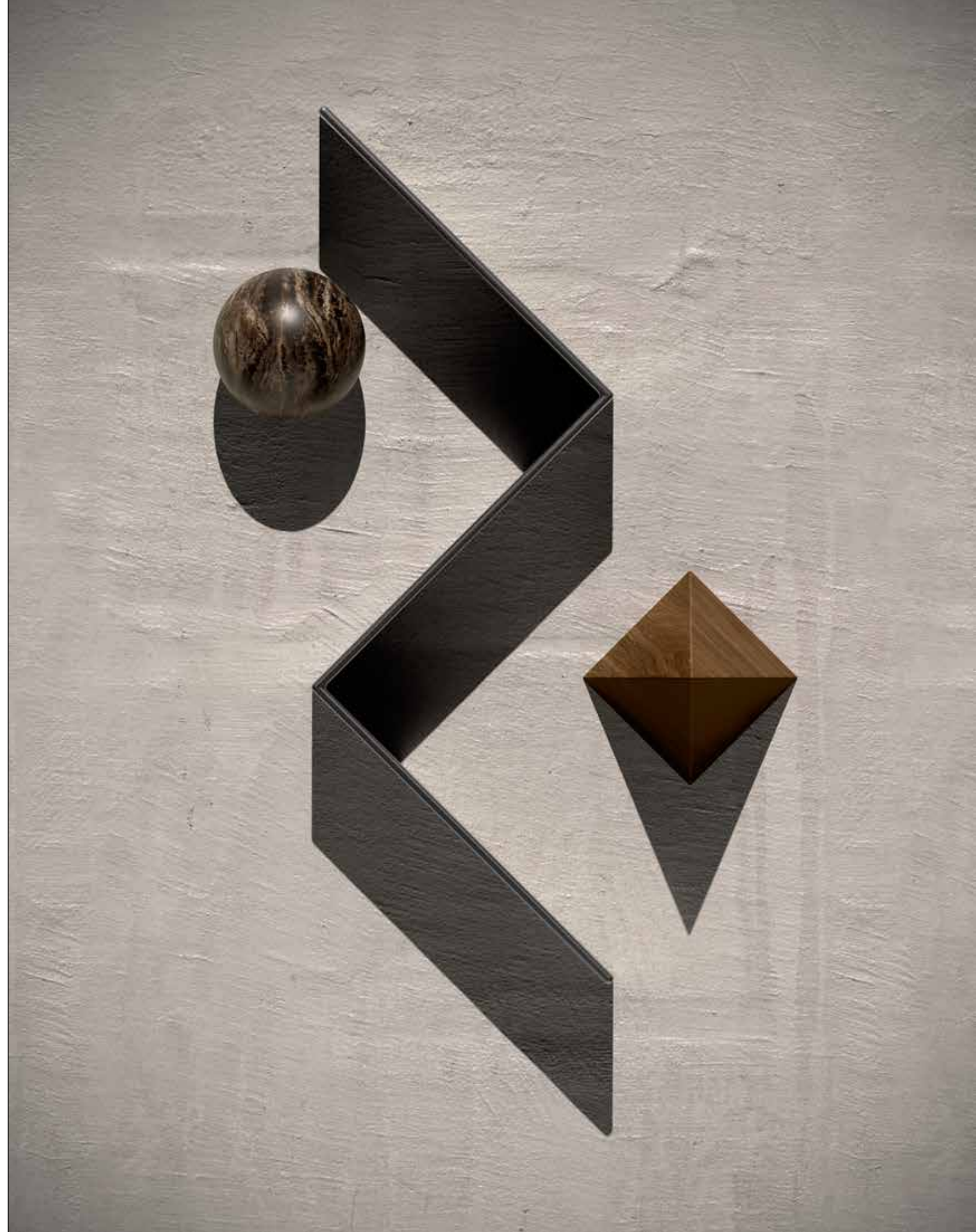



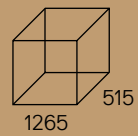
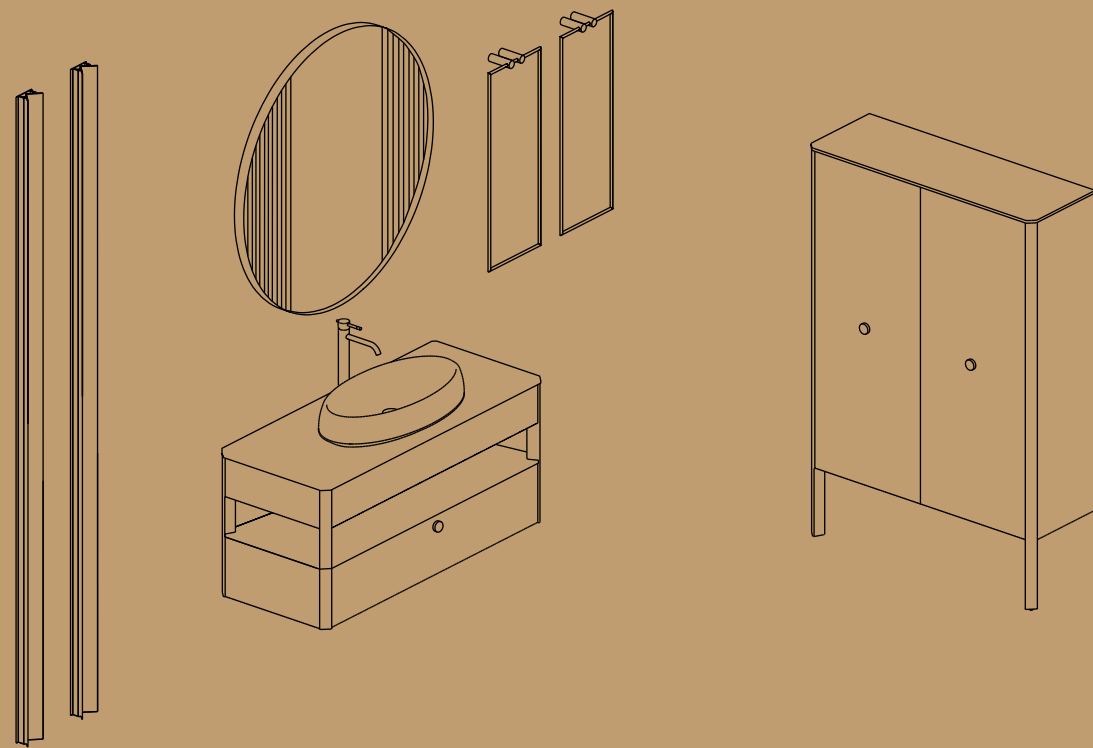

→ **Mobile lavabo/Composition with washbasin units/Composition avec éléments sous-vasque**
 Impiallacciato Rovere Termocotto 3D
 Rovere Termocotto veneered 3D
 Plaqué Rovere Termocotto 3D
 → **Piano/Top/Plan de toilette**
 Marmo Frappuccino levigato
 Frappuccino levigato marble
 Marbre Frappuccino levigato

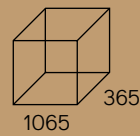

→ **Colonne/Hanging full-height units/Colonne**
 Impiallacciato Rovere Termocotto 3D
 Rovere Termocotto veneered 3D
 Plaqué Rovere Termocotto 3D

Elementi/Elements
Éléments

→ Lavabo/Basin/Vasque
 Pool 70M

→ Portasciugamano/Towel
 holder/Porte-serviettes
 Line

→ Lampade/Lamps/Lampes
 Victoria

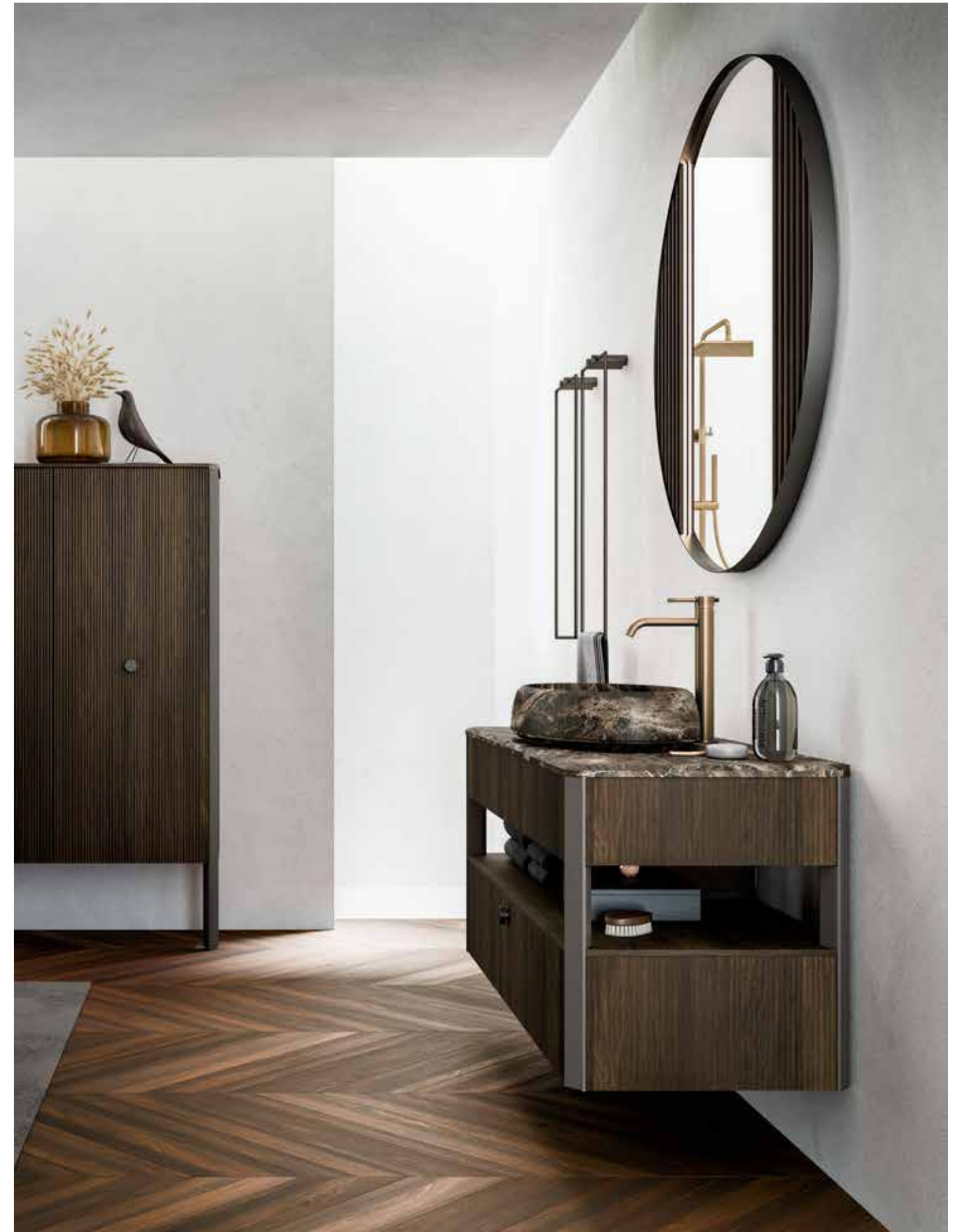



- IT** Tra i tanti materiali proposti per Honey, certamente l'effetto 3D, disponibile per legni e per laccati, esalta l'estetica della collezione valorizzandone la matericità.
- EN** Among the many materials proposed for Honey, certainly the 3D effect, available for woods and lacquers, enhances the aesthetics of the collection by enhancing its materiality.
- FR** Parmi les nombreux matériaux proposés par Honey, c'est certainement l'effet 3D, disponible pour bois et laqués, qui met le mieux en lumière l'esthétique de la collection en valorisant sa matérialité.



IT Il lavabo Pool 70M, oltre che in marmo, è disponibile anche in Solid Surface Bianco opaco: una valida alternativa per un cambio di stile e di immagine.

EN The Pool 70M washbasin, in addition to marble, is also available in matt Solid Surface Bianco: a valid alternative for a change of style and image.

FR Le vasque Pool 70M est disponible non seulement en marbre, mais également en Solid Surface Bianco mat : une alternative à considérer pour un changement de style et d'image.



Gli arredi diventano aspetti emozionali e viceversa, funzione e significato, in una rinnovata definizione dell'io.

SCENOGRAFIE COSMOPOLITE

EN COSMOPOLITAN SETTINGS
The furnishings become emotional aspects and vice-versa, function and meaning, in a renewed definition of the self.

FR SCÉNARIOS COSMOPOLITES
Les meubles deviennent des émotions et vice-versa, fonction et signification, pour une nouvelle définition du moi.





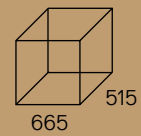
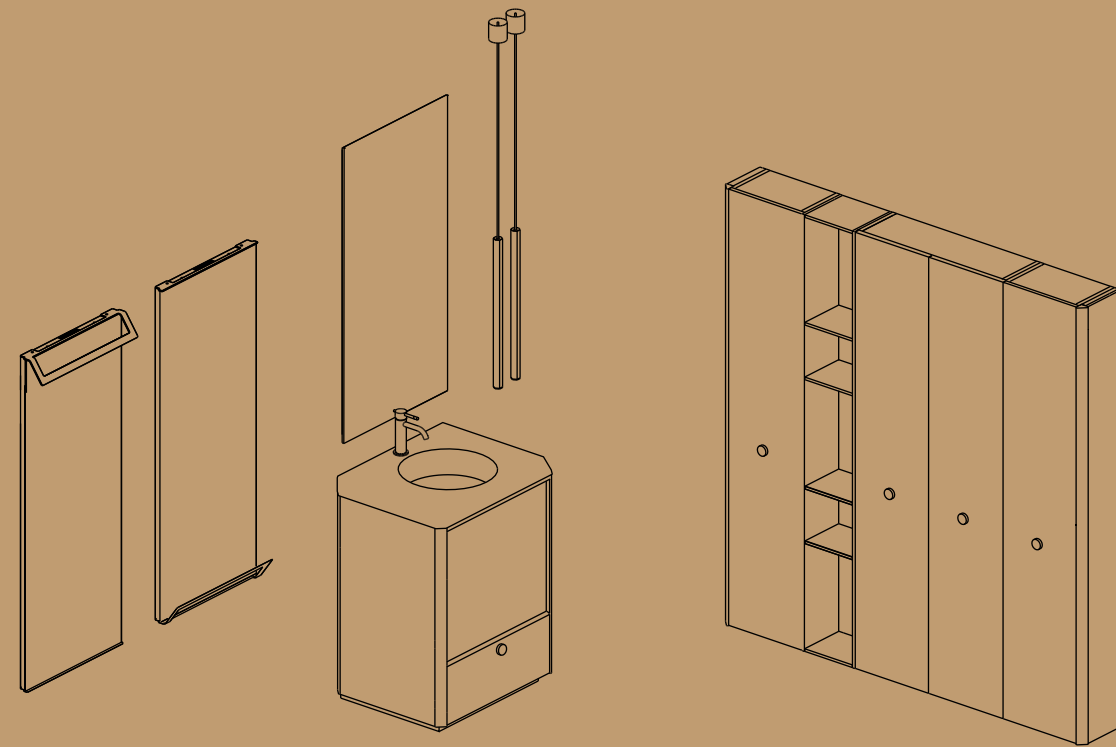

→ **Mobile lavabo/Composition with washbasin units/Composition avec éléments sous-vasque**
 Laminam Pietra Grey/
 Laccato opaco 04 Grigio Ghiaia
 Laminam Pietra Grey/
 04 Grigio Ghiaia matt lacquered
 Laminam Pietra Grey/
 Laqué mat 04 Grigio Ghiaia
 → **Piano lavabo/Top with integrated basin/Plan de toilette avec vasque moulée**
 Solysand/Laminam Pietra Grey

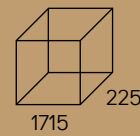

→ **Colonne/Hanging full-height units/Colonne**
 Laccato opaco 04 Grigio Ghiaia/
 Laccato opaco 33 Nichel
 04 Grigio Ghiaia matt lacquered/
 33 Nichel matt lacquered
 Laqué mat 04 Grigio Ghiaia/
 Laqué mat 33 Nichel

Elementi/Elements
Éléments

→ **Termoarredo/Heated towel racks/Radiateur décoratif**
 Frame

→ **Lampade/Lamps/Lampes**
 Vertical





- IT** Tutto coordinato ed abbinato: la finitura Pietra Grey è ripresa sia all'interno del lavabo che sul frontale del mobile.
- EN** All coordinated and matched: the Pietra Grey finish is repeated both inside the washbasin and on the front of the cabinet.
- FR** Tout en coordination et en combinaison : les finitions Pietra Grey sont reprises à l'intérieur du lavabo et sur la partie frontale du meuble.



IT I termoarredi Frame, implementabili con portasalviette o appendini, diventano quadri a parete, unendo la propria funzione di riscaldamento a quella d'arredo.

EN The Frame designer radiators, which can be implemented with towel racks or hangers, become wall paintings, combining their heating function with that of furnishing.

FR Les radiateurs que l'on peut agrémenter de porte-serviette ou de patères deviennent de véritables tableaux de paroi, unissant leur fonction de chauffage à celle d'ameublement.



Design Direction
Michele Marcon

Graphic Design
Metodo studio

Images
NuDesign

Color separation
NuDesign

Copywriting
Metodo studio

Printing
Grafiche Antiga

CERASA S.P.A.

via Borgo Nobili, 19
31010 Bibano di Godega
di S. Urbano (TV) Italy
Ph. +39 0438 783411
Fax +39 0438 783450
info@cerasa.it
www.cerasa.it

ICONE

BATHROOM
STORIES

CERASA.IT

CO CERASA®